



Town of Stow Conservation Department

380 Great Road
Stow, Massachusetts 01775

(978) 897-8615

FAX (978) 897-4534

conservation@stow-ma.gov

SOLICITATION FOR QUOTES

Boardwalk Trail Connector Project

SFQ 11-30-2022

QUOTES DUE: 1-9-2023

1. Instruction to Quote Submitters

The Town of Stow will receive Quotes at the Conservation Department, for the provision of a Boardwalk Trail Connector project until 12:00 Noon on January 9, 2023.

Envelopes containing Quotes shall be sealed, clearly marked and addressed to:

**Town of Stow
Conservation Department
Attn: Kathy Sferra
380 Great Road
Stow, MA 01775**

SFQ 11-30-2022 Conservation Boardwalk Trail Connector Project

The Town of Stow reserves the right to reject any and all Quotes, to waive any informality in the quoting process, and to make the award in the best interest of the Town.

A pre-bid walk through will be held at 12:00 PM on Friday, December 16, 2022, at Captain Sargent Conservation Area, Community Gardens, 36 Tuttle Lane, Stow, MA.

2. General Information and Quote Submission Requirements

2.1. Delivery of Quotes

Quotes will be received at the time and place set forth in the Instruction to Quote Submitters. Quotes received prior to the time established for the receipt of quotes will remain sealed and shall be securely kept by an officer whose duty will be to receive all quotes. At the established time quotes shall be publicly opened and read aloud. No responsibility will be attached to the officer for premature opening of a quote not properly addressed and identified.

If forwarded by mail, the sealed envelope containing the quote must be enclosed in another envelope addressed as specified.

The Town requires the following information to appear on the upper left-hand corner of the sealed quote envelope: **Conservation Boardwalk Trail Connector Project**

No quote received after the time established for the opening of quotes will be considered, regardless of the cause for the delay in the receipt of any such quote. Quoters are cautioned to allow ample time for transmittal of quotes by mail or otherwise. Quoters should secure correct information relative to probable time of arrival and distribution of mail. Make due allowance for possible delays in the receipts of quotes.

Electronic quotes will not be considered.

2.2. Questions

No oral interpretations will be made to any quoters as to the meaning of the specifications.

Every request for such an interpretation of project specifications shall be made in writing by a bidder and sent to Kathy Sferra Stow Conservation Director at Town of Stow 380 Great Road Stow, MA 01775. Questions must be submitted by 12:00 PM on Tuesday December 20, 2022. Questions regarding the quote document shall be directed to Kathy Sferra at (978) 897-8615 or conservation@stow-ma.gov.

Written responses will be emailed or faxed to all quoters on record as having received the Project Plans and Specifications. Every interpretation made to a Quoter will be sent as promptly as is practicable to all persons to whom the specifications have been issued. All such addenda shall become a part of the contract documents. Failure to send, or of any bidder to receive, any such interpretation shall not relieve any bidder from any obligation under this bid as submitted.

2.3. Quote Opening

If at the time of the scheduled quote opening, the Stow Town Building is closed due to uncontrolled events such as fire, snow, ice, wind, or building evacuation, the quote opening will be postponed until 2:00PM on the next business day. Quotes will be accepted until that date and time.

2.4. Modifying or Withdrawing A Quote

A Quoter may correct, modify, or withdraw a quote by written notice received by the Town prior to the time and date set for the opening. Quote modification must be submitted in a sealed envelope clearly labeled "Modification to Conservation Boardwalk Trail Connector Project." Each modification must be numbered in sequence and must reference the original Quote number.

After the opening, a Quoter may not change any provision of the quote in a manner prejudicial to the interest of the Town or fair competition. Minor informalities will be waived or the Quoter will be allowed to correct them. If a mistake and the intended quote are clearly evident on the face of the quote document, the mistake will be corrected to reflect the intended correct quote, and the Quoter will be notified in writing; the Quoter may not withdraw the quote. A Quoter may withdraw a quote if a mistake is clearly evident on the face of the quote document, but the intended correct quote is not similarly evident.

2.5 Unexpected Closures:

If, at the time of the scheduled receipt deadline, the Stow Town Building 380 Great Road, Stow, is closed due to uncontrolled events such as fire, snow, ice, wind, building evacuation, etc. the receipt of quotes will be postponed to the next normal business day at the time posted in the Solicitation for Quotes. Quotes will be accepted until that date and time.

2.6. Quote Documents Required for Submittal

All quotes shall be submitted on the prescribed form and shall be subject to all requirements stipulated in the specifications. All blank spaces for quote prices should be filled in, in both words and figures. In the event

that there is a discrepancy between the prices written in words and figures, the price written in words will govern. Erasures or other changes to quote forms must be explained or noted over the signature of the bidder.

Quoters are required to submit one copy of the quote.

The quote must include a Certificate of Non-Collusion, a Statement of Tax Compliance, and Quote Pricing Form be signed as follows: (1) if the Quoter is an individual, by him/her personally; (2) if the Quoter is a partnership, by the name of the partnership, followed by the signature of each general partner; and (3) if the Quoter is a corporation, by the authorized officer, whose signature must be attested to by the Clerk/Secretary of the corporation and the corporate seal affixed.

2.7. Payment Bond

Within 10 days of the notification of the contract award, the quoter must obtain a 50% payment bond. A payment bond shall be (a) in the form satisfactory to the Town, (b) with a surety company qualified to do business in the Commonwealth and satisfactory to the Town, and (c) conditioned upon the faithful performance by the principal of the agreements contained in the contract. The amount of the payment bond shall be at least equal to 50% of the total amount of the contract.

2.8. Comprehensive General Liability Insurance

The contractor shall obtain and maintain Public Liability Insurance with an insurance company licensed to do business in Massachusetts and satisfactory to the Town of Stow so as to save the Town harmless from any and all claims for damages arising out of bodily injury or destruction of property caused by accident resulting from the use of implements, equipment, or labor used in the performance of the contract or from any neglect, default, or omission or want of proper care, or misconduct on the part of the contractor or for anyone in his employ during the execution of the work. The contractor shall file Certificates of Insurance acceptable to the Town prior to commencement of the Work. Each policy shall contain a provision that the policy will not be canceled or allowed to expire until at least 30 days prior written notice has been given to the Owner. The contractor shall cause the liability coverage required by the Contract to include: (1) the Town as additional insureds for claims caused in whole or in part by the contractor's negligent acts or omissions during the contractor's operations; and (2) the Town as an additional insured for claims caused in whole or in part by the contractor's negligent acts or omissions during the contractor's completed operations.

The Town will require the Contractor to provide a Certificate of Insurance (Acord Form 25) written to include the following limits:

- 1) General Liability of at least \$1,000,000 Occurrence and \$3,000,000 General Aggregate. The Municipality should be named as an "Additional Insured".
- 2) Automobile Liability (applicable for any contractor who has an automobile operating exposure) of at least \$1,000,000 Bodily Injury and Property Damage per accident. The Municipality should be named as an "Additional Insured".
- 3) Workers' Compensation Insurance as required by law. Include Employers Liability Part B

Prior to the effective date of any cancellation of the required policies, the contractor shall obtain new insurance to cover the policies so canceled and shall provide certificates stating that such insurance is in effect.

The Contractor agrees to save, defend, indemnify and hold harmless the Town of Stow against any and all suits, claims or liabilities of any name, nature or description arising out of or in consequence of the acts

or omissions of its agents, servants or employees in the performance of the obligations under this contract or by reason of its failure to fully comply with the terms of this contract, such indemnity to run to the Town officers, agents and employees of the Town of Stow.

In claims against any person or entity indemnified under this Section by an employee of the Contractor, a Subcontractor, anyone directly or indirectly employed by them or anyone for whose acts they may be liable, the indemnification obligation under this Section shall not be limited by a limitation on amount or type of damages, compensation or benefits payable by or for the Contractor or Subcontractor under workers' compensation acts, disability benefit acts or other employee benefit acts.

2.9 Breach of Contract

In the case of failure on the part of the contractor to execute the work as per agreement, the Committee reserves the right to terminate the contract, satisfying its wants through another contractor, and the Committee may collect from the original contractor any difference in price because of such failure on the part of the original contractor. "Failure" shall be interpreted as meaning willful non-compliance of any item included in the specifications.

This contract may not be terminated for any other reason than that set forth in the above paragraph, unless by mutual consent of both parties to the contract, and then only if a minimum of thirty (30) days' notice of intent to seek to terminate the contract is given in writing to all parties to the contract.

Exercise of the rights herein specified shall not impair or affect the Town's right to recover the damages for breach of contract.

2.10 Contractual Liability

Failure to perform when such failure is due to an act of God, public enemy, fire, strikes, labor difficulties, transportation embargoes, or other similar causes beyond the control of the contractor, shall be good and sufficient reason for excuse from contractual liability.

2.11 Good Faith, Fraud, and Collusion

The quoter hereby certifies that no officer, agent or employee of the Town of Stow has a special interest in the SFQ; that the proposer is competing solely on their own behalf without connection with, or obligation to, any undisclosed person or firm; that this quote is made in good faith without fraud, collusion or connection of any kind with any other quoter for the same work (See Non-Collusion Form). The Form must be executed and returned with the proposal.

2.12 Acknowledgment of ADA and Section 504

The Town acknowledges the existence of the Americans with Disabilities Act (ADA) of 1990, & Section 504 of the Rehabilitation Act of 1973. The rights guaranteed within these Acts shall apply to this contract.

2.13 Payment Schedule

Final payment will not be released until full satisfactory completion of the project and all contract terms and obligations are met.

2.14. Liability

Town's Liability: The Town's liability under this Contract shall be limited to the payments due thereunder. In no event shall the Town be liable for any additional amounts, including without limitation, any indirect, special or consequential damages.

Protection Against Liability: The Contractor acknowledges and agrees that he is responsible as an independent Contractor for all operations under this Contract and for all acts of employees and agents thereunder, and agrees that he will indemnify, exonerate and hold harmless the Town and its officers, boards, employees, agents and officials, from and against any and all loss, damage, cost, charge, expense and claim, which may be made against it or them or to which it or they may be subject by reason of any alleged act, action, neglect, omission or default on the part of the Contractor or any of their agents or employees and will pay promptly on demand all costs and expenses of the investigation and defense thereof, including attorneys' fees and expenses. If any such claim is made, the Town may retain out of any payments, then thereafter due to the Contractor, a sufficient amount to protect it completely against such claim, costs and expenses.

2.15 Licensing

The contractor shall possess and comply with all required and necessary licenses as may be specified by Federal, State and/or Local authorities, related to the delivery of services referred to in this SFQ.

2.16 Insurance Coverage

Within (5) days after award of this contract, and prior to the commencement of any work activity, the contractor shall deposit certificates from insurers clearly stating that the insurance policies required in the following paragraphs have been issued to the contractor. The certificate must be in a form satisfactory to the Town. Liability policies shall name the Town of Stow as an additional insured.

2.17 Worker's Compensation

The contractor shall, before commencing the contract, provide by insurance for the payment of compensation, professional liability, and the furnishing of other benefits under Chapter 152 of the General Laws to all persons employed under the contract, and shall continue such insurance in force and effect during the term thereof. Statutory limits shall apply.

2.18. Prevailing Wage Laws

The quoter must comply with Massachusetts Prevailing Wage Laws.

2.19. Miscellaneous

The Town of Stow, Massachusetts is an exempt purchaser under the Sales Act, Chapter 14 of the Acts of 1966 to the extent that materials and supplies are used or incorporated in this bid. The Town's Sales Tax Exempt Number is 046001313 and a certificate will be provided upon the signing of the contract.

3. Drawings and Specifications

3.1 Project Description

The Town of Stow Conservation Commission is working in partnership with the Stow Conservation Trust to construct a pedestrian/bicycle boardwalk through a wetland. When complete, the boardwalk will provide a

trail connection between two properties owned by the Town and the Trust, respectively. The boardwalk is 360' long and four feet in width. The boardwalk shall be constructed using pipe and auger construction with wood decking with 8-10 foot spans, and one eight foot wide bump out. All materials shall be supplied by the selected bidder.

The project site is approximately 750 feet from a paved public way and accessible within 50 feet by light truck, ATV or similar equipment. The trail will be closed to the public during construction.

The wetland is frequently inundated with standing water; however the water level does not exceed eight inches during the wettest periods. There is no stream or flow. The boardwalk should be constructed to be at least eight inches above the ground surface. There is an existing trail in the location of the boardwalk and all clearing, and removal of vegetation will be the responsibility of the Town/Trust and will be completed prior to the commencement of work. The Town/Trust will also be responsible for any trail construction and widening beyond the limits of the boardwalk.

Work will be conducted under Order of Conditions #299-719 and plans and specifications contained in the Notice of Intent (see attached). No heavy equipment or machinery is permitted within the wetland or 35' buffer to the wetland.

3.2 Workmanship

All work must be completed by a general contractor licensed to conduct business in Massachusetts. Skilled and Licensed craftsmen, shall perform the work as indicated on the Drawings and Specifications.

All work shall be performed to the satisfaction of the Town and the Town's decisions on workmanship shall be final.

3.3. Site Conditions and Requirements

Personal vehicle parking is permitted at the Stow Community Gardens, 36 Tuttle Lane, Stow, MA. Work may take place Monday - Friday between 7 AM to 4:30 PM. At the sole discretion of the Town, Saturday and Sunday work will be possible if pre-arranged.

All trash and debris shall be removed from the project site at the completion of work.

The Town is not responsible for tools or equipment left on site.

4. Minimum Criteria

- 4.1. Quoter must have been in the business of this type of work for a minimum of five years and must have successfully completed at least three boardwalk projects.
- 4.2. Quoter must supply references for at least three projects of similar size and scope as this project during the past three years. The references should include the name of the project, description, address, contact person, and phone number as well as relevant photographs of the work.
- 4.3. Quoter must complete, sign, and include the Quote Pricing Form, the Certificate of Non-Collusion, and the Statement of Tax Compliance.
- 4.4. No Bond Bid is required.
- 4.5. OSHA CERTIFICATION: In accordance with M.G.L.c. 30, Section 39S and c. 149, Section 44E, quoters shall include with their quotes a certificate indicating that all employees to be employed at the worksite will have successfully completed a course in construction safety and health approved by the United States

Occupational Safety and Health Administration that is at least 10 hours in duration at the time the employee begins work and who shall furnish documentation of successful completion of said course with the first certified payroll report for each employee.

5. Rule for Award

- 5.1. The contract will be awarded to the responsible and eligible quoter offering the lowest total price for the project.
- 5.2. No award will be made to any quoter who cannot satisfy the Town that the quoter has sufficient ability and experience in this work and sufficient resources to enable the quoter to complete the work successfully within the time allowed. The Town's decision or judgment on these matters will be final, conclusive and binding.
- 5.3. The Town may make such investigations as the Town deems necessary and the quoter shall furnish to the Town all such information and data for this purpose as the Town may request.
- 5.4. The contract will be awarded within sixty days after the quote opening unless the time for the award is extended by mutual consent of the parties. Contractor's quotes shall be valid for sixty days.

6. Town's Right To Reject Bids

- 6.1. The Awarding Authority reserves the right to reject any or all quotes, if it is in the public interest to do so.
- 6.2. The Town may consider informal any quotes not prepared and submitted in accordance with the provisions hereof and may waive any informality or reject any and all quotes, should the Town deem it to be in the public interest.
- 6.3. The Town may also reject quotes which in its sole judgment are incomplete, conditional, obscure, or not responsive or which contain additional not called for erasures not properly initialed, alterations or similar irregularities, or the Town may waive such omissions, conditions or irregularities, if considered minor.

7. Additional Contract Terms and Conditions

This quote is being conducted according with Massachusetts General Laws, Chapter 30, Section 39M and all acts in amendment of or supplementary to said Chapter are a part of this contract and are incorporated herein as fully as if here set forth.

The successful quoter must agree to commence work upon receipt of Notice to Proceed, and to cause all work of this Contract to be Substantially Completed not later than 120 calendar days after the Notice to Proceed.

8. Liquidated Damages:

Liquidated Damages: If the Work on site is not substantially complete within the time specified, it shall be understood and agreed that the Contractor shall pay the Owner, not as a penalty but as liquidated damages, the following sum for each calendar day after and including the day of Substantial Completion for that site, as further provided in the Contract Documents.

1. Amount for Liquidated Damages: \$250 per day.

CERTIFICATE OF NON-COLLUSION

The undersigned certifies under penalties of perjury that this quote or proposal has been made and submitted in good faith and without collusion or fraud with any other person. As used in this certification, the word “person” shall mean any natural person, business, partnership, corporation, union, committee, club, or other organization, entity, or group of individuals.

(Signature of person signing quote)

(Typed name of person signing quote)

(Name of business)

OSHA CERTIFICATION

The undersigned agrees that if he is selected as the contractor, he will comply with the provisions of M.G.L.Chapter 30, Section 39S.

The undersigned certifies, under penalties of perjury, that he is able to furnish labor that can work in harmony with all other elements of labor employed or to be employed in the work; that all employees to be employed at the worksite will have successfully completed a course in construction safety and health approved by the United States Occupational Safety and Health Administration that is at least 10 hours in duration at the time the employee begins work and who shall furnish documentation of successful completion of said course with the first certified payroll report for each employee; and that all employees to be employed in the work subject to this bid have successfully completed a course in construction safety and health approved by the United States Occupational Safety and Health Administration that is at least 10 hours in duration.

Signature: _____

-BIDDER’S CERTIFICATION REGARDING PAYMENT OF PREVAILING WAGES

The undersigned bidder hereby certifies, under the pains and penalties of perjury, that the foregoing bid is based upon the payment to laborers to the employed on the project of wages in an amount no less than the applicable prevailing wage rates established for the project by the Massachusetts Department of Labor and Industries. The undersigned bidder agrees to indemnify the awarding authority for, from and against any loss, expenses, damages, action or claims, including any expense incurred in connection with any delay or stoppage of the project work, arising out of or as a result of (1) the failure of the said bid to be based upon the payment of the said applicable prevailing wage rates, or (2) the failure of the bidder, if selected as the contractor, to pay laborers employed on the project the said applicable prevailing wages.

Signature: _____

STATEMENT OF STATE TAX COMPLIANCE

Pursuant to MGL Chapter 62C, S. 49A, as amended, I

NAME & TITLE

authorized signatory for _____
CONTRACTING PARTY

whose principal place of business is at _____

ADDRESS

do hereby certify under the pains and penalties of perjury that _____

_____ has complied with all laws of
CONTRACTING PARTY

the Commonwealth relating to taxes, reporting of employees and contractors, and withholding and remitting child support.

CONTRACTING PARTY'S SOCIAL
SECURITY OR FEDERAL I.D. NUMBER:

AUTHORIZED SIGNATURE

DATE

GENERAL QUOTE PRICING FORM

Vendor Name:

Vendor Address:

Telephone Number:

Email:

This bid includes addenda number (s) _____

QUOTE for the Stow Conservation Boardwalk Trail Connector Project:

\$ _____ (TOTAL LABOR ONLY)

\$ _____ (TOTAL MATERIALS ONLY)

\$ _____ (TOTAL OTHER COSTS (specify) _____)

\$ _____ (TOTAL QUOTE PRICE = SUM OF LABOR + MATERIALS + OTHER)

TOTAL QUOTE PRICE for the Stow Conservation Boardwalk Trail Connector Project:
(written)

WORK EXAMPLES

LIST LOCATION OF THREE SIMILAR BOARDWALK PROJECTS AND CLIENT CONTACT INFORMATION

The references should include the name of the project, description, address, contact person, and phone number as well as relevant photographs of the work.

1.

2.

3.

The names of all persons, firms and corporations furnishing to the undersigned labor or labor and materials for the class or classes or part thereof of work for which the provisions of the section of the specifications for this trade require a listing in this paragraph, (including the undersigned if customarily furnished by persons on his/her own payroll and in the absence of a contrary provision in the specifications) the name of each such class of work or part thereof and the quote price for each such class of work or part thereof are:

<u>Name</u>	<u>Class of Work</u>	<u>Quote Price</u>
_____	_____	_____
_____	_____	_____
_____	_____	_____

(Do not give price for any class or part thereof furnished by the undersigned.)

Signature: _____

Title: _____

Date: _____

NOTICE:

Proposal should be signed in ink by a person having proper legal authority, and the person's title should be given such as "owner" in the case of individual; "partner" in the case of a general partnership; "president", "treasurer" or other authorized office in the case of a corporation.

PREVAILING WAGES RATES

ATTACHED

(39 PAGES)



**THE COMMONWEALTH OF MASSACHUSETTS
EXECUTIVE OFFICE OF LABOR AND WORKFORCE DEVELOPMENT
DEPARTMENT OF LABOR STANDARDS**

Prevailing Wage Rates

**As determined by the Director under the provisions of the
Massachusetts General Laws, Chapter 149, Sections 26 to 27H**

CHARLES D. BAKER
Governor

ROSALIN ACOSTA
Secretary

KARYN E. POLITO
Lt. Governor

MICHAEL FLANAGAN
Director

Awarding Authority: Town of Stow
Contract Number: _____ **City/Town:** STOW
Description of Work: Install 360 feet of pedestrian and bicycle boardwalk over wetland conservation area
Job Location: Tuttle Road

Information about Prevailing Wage Schedules for Awarding Authorities and Contractors

- **The wage rates will remain in effect for the duration of the project, except in the case of multi-year public construction projects. For construction projects lasting longer than one year, awarding authorities must request an updated wage schedule no later than two weeks before the anniversary of the date the contract was executed by the awarding authority and the general contractor.** For multi-year CM AT RISK projects, the awarding authority must request an annual update no later than two weeks before the anniversary date, determined as the earlier of: (a) the execution date of the GMP Amendment, or (b) the execution date of the first amendment to permit procurement of construction services. The annual update requirement is not applicable to 27F "rental of equipment" contracts. **The updated wage schedule must be provided to all contractors, including general and sub-contractors, working on the construction project.**
- This wage schedule applies only to the specific project referenced at the top of this page and uniquely identified by the "Wage Request Number" on all pages of this schedule.
- An Awarding Authority must request an updated wage schedule if it has not opened bids or selected a contractor within 90 days of the date of issuance of the wage schedule. For CM AT RISK projects (bid pursuant to G.L. c.149A), the earlier of: (a) the execution date of the GMP Amendment, or (b) the bid for the first construction scope of work must be within 90-days of the wage schedule issuance date.
- The wage schedule shall be incorporated in any advertisement or call for bids for the project as required by M.G.L. c. 149, § 27. The wage schedule shall be made a part of the contract awarded for the project. The wage schedule must be posted in a conspicuous place at the work site for the life of the project in accordance with M.G.L. c. 149 § 27. The wages listed on the wage schedule must be paid to employees performing construction work on the project whether they are employed by the prime contractor, a filed sub-bidder, or a sub-contractor.
- Apprentices working on the project are required to be registered with the Massachusetts Division of Apprentice Standards (DAS). Apprentices must keep their apprentice identification card on their persons during all work hours on the project. An apprentice registered with DAS may be paid the lower apprentice wage rate at the applicable step as provided on the prevailing wage schedule. **Any apprentice not registered with DAS regardless of whether they are registered with another federal, state, local, or private agency must be paid the journeyworker's rate.**
- Every contractor or subcontractor working on the construction project must submit weekly payroll reports and a Statement of Compliance directly to the awarding authority by mail or email and keep them on file for three years. Each weekly payroll report must contain: the employee's name, address, occupational classification, hours worked, and wages paid. Do not submit weekly payroll reports to DLS. For a sample payroll reporting form go to <http://www.mass.gov/dols/pw>.
- Contractors with questions about the wage rates or classifications included on the wage schedule have an affirmative obligation to inquire with DLS at (617) 626-6953.
- Contractors must obtain the wage schedules from awarding authorities. Failure of a contractor or subcontractor to pay the prevailing wage rates listed on the wage schedule to all employees who perform construction work on the project is a violation of the law and subjects the contractor or subcontractor to civil and criminal penalties.
- Employees not receiving the prevailing wage rate set forth on the wage schedule may file a complaint with the Fair Labor Division of the office of the Attorney General at (617) 727-3465.

Classification	Effective Date	Base Wage	Health	Pension	Supplemental Unemployment	Total Rate
Construction						
(2 AXLE) DRIVER - EQUIPMENT <i>TEAMSTERS JOINT COUNCIL NO. 10 ZONE B</i>	12/01/2021	\$35.95	\$13.41	\$16.01	\$0.00	\$65.37
(3 AXLE) DRIVER - EQUIPMENT <i>TEAMSTERS JOINT COUNCIL NO. 10 ZONE B</i>	12/01/2021	\$36.02	\$13.41	\$16.01	\$0.00	\$65.44
(4 & 5 AXLE) DRIVER - EQUIPMENT <i>TEAMSTERS JOINT COUNCIL NO. 10 ZONE B</i>	12/01/2021	\$36.14	\$13.41	\$16.01	\$0.00	\$65.56
ADS/SUBMERSIBLE PILOT <i>PILE DRIVER LOCAL 56 (ZONE 1)</i>	08/01/2020	\$103.05	\$9.40	\$23.12	\$0.00	\$135.57
For apprentice rates see "Apprentice- PILE DRIVER"						
AIR TRACK OPERATOR <i>LABORERS - ZONE 2</i>	06/01/2022	\$37.06	\$9.10	\$16.64	\$0.00	\$62.80
	12/01/2022	\$37.91	\$9.10	\$16.64	\$0.00	\$63.65
	06/01/2023	\$38.81	\$9.10	\$16.64	\$0.00	\$64.55
	12/01/2023	\$39.71	\$9.10	\$16.64	\$0.00	\$65.45
For apprentice rates see "Apprentice- LABORER"						
AIR TRACK OPERATOR (HEAVY & HIGHWAY) <i>LABORERS - ZONE 2 (HEAVY & HIGHWAY)</i>	12/01/2021	\$36.16	\$9.10	\$16.64	\$0.00	\$61.90
For apprentice rates see "Apprentice- LABORER (Heavy and Highway)"						
ASBESTOS REMOVER - PIPE / MECH. EQUIPT. <i>HEAT & FROST INSULATORS LOCAL 6 (BOSTON)</i>	12/01/2020	\$38.10	\$12.80	\$9.45	\$0.00	\$60.35
ASPHALT RAKER <i>LABORERS - ZONE 2</i>	06/01/2022	\$36.56	\$9.10	\$16.64	\$0.00	\$62.30
	12/01/2022	\$37.41	\$9.10	\$16.64	\$0.00	\$63.15
	06/01/2023	\$38.31	\$9.10	\$16.64	\$0.00	\$64.05
	12/01/2023	\$39.21	\$9.10	\$16.64	\$0.00	\$64.95
For apprentice rates see "Apprentice- LABORER"						
ASPHALT RAKER (HEAVY & HIGHWAY) <i>LABORERS - ZONE 2 (HEAVY & HIGHWAY)</i>	12/01/2021	\$35.66	\$9.10	\$16.64	\$0.00	\$61.40
For apprentice rates see "Apprentice- LABORER (Heavy and Highway)"						
ASPHALT/CONCRETE/CRUSHER PLANT-ON SITE <i>OPERATING ENGINEERS LOCAL 4</i>	06/01/2022	\$52.38	\$14.25	\$16.05	\$0.00	\$82.68
	12/01/2022	\$53.63	\$14.25	\$16.05	\$0.00	\$83.93
	06/01/2023	\$54.88	\$14.25	\$16.05	\$0.00	\$85.18
	12/01/2023	\$56.13	\$14.25	\$16.05	\$0.00	\$86.43
	06/01/2024	\$57.43	\$14.25	\$16.05	\$0.00	\$87.73
	12/01/2024	\$58.88	\$14.25	\$16.05	\$0.00	\$89.18
	06/01/2025	\$60.18	\$14.25	\$16.05	\$0.00	\$90.48
	12/01/2025	\$61.63	\$14.25	\$16.05	\$0.00	\$91.93
	06/01/2026	\$62.93	\$14.25	\$16.05	\$0.00	\$93.23
	12/01/2026	\$64.38	\$14.25	\$16.05	\$0.00	\$94.68
For apprentice rates see "Apprentice- OPERATING ENGINEERS"						

Classification	Effective Date	Base Wage	Health	Pension	Supplemental Unemployment	Total Rate
BACKHOE/FRONT-END LOADER <i>OPERATING ENGINEERS LOCAL 4</i>	06/01/2022	\$52.38	\$14.25	\$16.05	\$0.00	\$82.68
	12/01/2022	\$53.63	\$14.25	\$16.05	\$0.00	\$83.93
	06/01/2023	\$54.88	\$14.25	\$16.05	\$0.00	\$85.18
	12/01/2023	\$56.13	\$14.25	\$16.05	\$0.00	\$86.43
	06/01/2024	\$57.43	\$14.25	\$16.05	\$0.00	\$87.73
	12/01/2024	\$58.88	\$14.25	\$16.05	\$0.00	\$89.18
	06/01/2025	\$60.18	\$14.25	\$16.05	\$0.00	\$90.48
	12/01/2025	\$61.63	\$14.25	\$16.05	\$0.00	\$91.93
	06/01/2026	\$62.93	\$14.25	\$16.05	\$0.00	\$93.23
	12/01/2026	\$64.38	\$14.25	\$16.05	\$0.00	\$94.68
For apprentice rates see "Apprentice- OPERATING ENGINEERS"						
BARCO-TYPE JUMPING TAMPER <i>LABORERS - ZONE 2</i>	06/01/2022	\$36.56	\$9.10	\$16.64	\$0.00	\$62.30
	12/01/2022	\$37.41	\$9.10	\$16.64	\$0.00	\$63.15
	06/01/2023	\$38.31	\$9.10	\$16.64	\$0.00	\$64.05
	12/01/2023	\$39.21	\$9.10	\$16.64	\$0.00	\$64.95
For apprentice rates see "Apprentice- LABORER"						
BLOCK PAVER, RAMMER / CURB SETTER <i>LABORERS - ZONE 2</i>	06/01/2022	\$37.06	\$9.10	\$16.64	\$0.00	\$62.80
	12/01/2022	\$37.91	\$9.10	\$16.64	\$0.00	\$63.65
	06/01/2023	\$38.81	\$9.10	\$16.64	\$0.00	\$64.55
	12/01/2023	\$39.71	\$9.10	\$16.64	\$0.00	\$65.45
For apprentice rates see "Apprentice- LABORER"						
BLOCK PAVER, RAMMER / CURB SETTER (HEAVY & HIGHWAY) <i>LABORERS - ZONE 2 (HEAVY & HIGHWAY)</i>	12/01/2021	\$36.16	\$9.10	\$16.64	\$0.00	\$61.90
For apprentice rates see "Apprentice- LABORER (Heavy and Highway)"						
BOILER MAKER <i>BOILERMAKERS LOCAL 29</i>	01/01/2020	\$46.10	\$7.07	\$17.98	\$0.00	\$71.15

Apprentice - BOILERMAKER - Local 29

Effective Date - 01/01/2020

Step	percent	Apprentice Base Wage	Health	Pension	Supplemental Unemployment	Total Rate
1	65	\$29.97	\$7.07	\$11.69	\$0.00	\$48.73
2	65	\$29.97	\$7.07	\$11.69	\$0.00	\$48.73
3	70	\$32.27	\$7.07	\$12.59	\$0.00	\$51.93
4	75	\$34.58	\$7.07	\$13.49	\$0.00	\$55.14
5	80	\$36.88	\$7.07	\$14.38	\$0.00	\$58.33
6	85	\$39.19	\$7.07	\$15.29	\$0.00	\$61.55
7	90	\$41.49	\$7.07	\$16.18	\$0.00	\$64.74
8	95	\$43.80	\$7.07	\$17.09	\$0.00	\$67.96

Notes:

Apprentice to Journeyworker Ratio:1:4

Classification	Effective Date	Base Wage	Health	Pension	Supplemental Unemployment	Total Rate
BRICK/STONE/ARTIFICIAL MASONRY (INCL. MASONRY WATERPROOFING) <i>BRICKLAYERS LOCAL 3 (LOWELL)</i>	08/01/2022	\$57.01	\$11.49	\$21.65	\$0.00	\$90.15
	02/01/2023	\$58.21	\$11.49	\$21.65	\$0.00	\$91.35
	08/01/2023	\$60.26	\$11.49	\$21.65	\$0.00	\$93.40
	02/01/2024	\$61.51	\$11.49	\$21.65	\$0.00	\$94.65
	08/01/2024	\$63.61	\$11.49	\$21.65	\$0.00	\$96.75
	02/01/2025	\$64.91	\$11.49	\$21.65	\$0.00	\$98.05
	08/01/2025	\$67.06	\$11.49	\$21.65	\$0.00	\$100.20
	02/01/2026	\$68.41	\$11.49	\$21.65	\$0.00	\$101.55
	08/01/2026	\$70.61	\$11.49	\$21.65	\$0.00	\$103.75
	02/01/2027	\$72.01	\$11.49	\$21.65	\$0.00	\$105.15

Apprentice - BRICK/PLASTER/CEMENT MASON - Local 3 Lowell

Effective Date - 08/01/2022

Step	percent	Apprentice Base Wage	Health	Pension	Supplemental Unemployment	Total Rate
1	50	\$28.51	\$11.49	\$21.65	\$0.00	\$61.65
2	60	\$34.21	\$11.49	\$21.65	\$0.00	\$67.35
3	70	\$39.91	\$11.49	\$21.65	\$0.00	\$73.05
4	80	\$45.61	\$11.49	\$21.65	\$0.00	\$78.75
5	90	\$51.31	\$11.49	\$21.65	\$0.00	\$84.45

Effective Date - 02/01/2023

Step	percent	Apprentice Base Wage	Health	Pension	Supplemental Unemployment	Total Rate
1	50	\$29.11	\$11.49	\$21.65	\$0.00	\$62.25
2	60	\$34.93	\$11.49	\$21.65	\$0.00	\$68.07
3	70	\$40.75	\$11.49	\$21.65	\$0.00	\$73.89
4	80	\$46.57	\$11.49	\$21.65	\$0.00	\$79.71
5	90	\$52.39	\$11.49	\$21.65	\$0.00	\$85.53

Notes:

Apprentice to Journeyworker Ratio:1:5

BULLDOZER/GRADER/SCRAPER <i>OPERATING ENGINEERS LOCAL 4</i>	06/01/2022	\$51.82	\$14.25	\$16.05	\$0.00	\$82.12
	12/01/2022	\$53.05	\$14.25	\$16.05	\$0.00	\$83.35
	06/01/2023	\$54.29	\$14.25	\$16.05	\$0.00	\$84.59
	12/01/2023	\$55.53	\$14.25	\$16.05	\$0.00	\$85.83
	06/01/2024	\$56.81	\$14.25	\$16.05	\$0.00	\$87.11
	12/01/2024	\$58.25	\$14.25	\$16.05	\$0.00	\$88.55
	06/01/2025	\$59.53	\$14.25	\$16.05	\$0.00	\$89.83
	12/01/2025	\$60.97	\$14.25	\$16.05	\$0.00	\$91.27
	06/01/2026	\$62.25	\$14.25	\$16.05	\$0.00	\$92.55
	12/01/2026	\$63.69	\$14.25	\$16.05	\$0.00	\$93.99

For apprentice rates see "Apprentice- OPERATING ENGINEERS"

CAISSON & UNDERPINNING BOTTOM MAN <i>LABORERS - FOUNDATION AND MARINE</i>	12/01/2021	\$42.33	\$9.10	\$17.72	\$0.00	\$69.15
--	------------	---------	--------	---------	--------	---------

For apprentice rates see "Apprentice- LABORER"

Classification	Effective Date	Base Wage	Health	Pension	Supplemental Unemployment	Total Rate
CAISSON & UNDERPINNING LABORER <i>LABORERS - FOUNDATION AND MARINE</i>	12/01/2021	\$41.18	\$9.10	\$17.72	\$0.00	\$68.00
For apprentice rates see "Apprentice- LABORER"						
CAISSON & UNDERPINNING TOP MAN <i>LABORERS - FOUNDATION AND MARINE</i>	12/01/2021	\$41.18	\$9.10	\$17.72	\$0.00	\$68.00
For apprentice rates see "Apprentice- LABORER"						
CARBIDE CORE DRILL OPERATOR <i>LABORERS - ZONE 2</i>	06/01/2022	\$36.56	\$9.10	\$16.64	\$0.00	\$62.30
	12/01/2022	\$37.41	\$9.10	\$16.64	\$0.00	\$63.15
	06/01/2023	\$38.31	\$9.10	\$16.64	\$0.00	\$64.05
	12/01/2023	\$39.21	\$9.10	\$16.64	\$0.00	\$64.95
For apprentice rates see "Apprentice- LABORER"						
CARPENTER <i>CARPENTERS -ZONE 2 (Eastern Massachusetts)</i>	09/01/2022	\$45.18	\$8.68	\$19.97	\$0.00	\$73.83
	03/01/2023	\$45.78	\$8.68	\$19.97	\$0.00	\$74.43

Apprentice - CARPENTER - Zone 2 Eastern MA

Effective Date - 09/01/2022

Step	percent	Apprentice Base Wage	Health	Pension	Supplemental Unemployment	Total Rate
1	50	\$22.59	\$8.68	\$1.73	\$0.00	\$33.00
2	60	\$27.11	\$8.68	\$1.73	\$0.00	\$37.52
3	70	\$31.63	\$8.68	\$14.78	\$0.00	\$55.09
4	75	\$33.89	\$8.68	\$14.78	\$0.00	\$57.35
5	80	\$36.14	\$8.68	\$16.51	\$0.00	\$61.33
6	80	\$36.14	\$8.68	\$16.51	\$0.00	\$61.33
7	90	\$40.66	\$8.68	\$18.24	\$0.00	\$67.58
8	90	\$40.66	\$8.68	\$18.24	\$0.00	\$67.58

Effective Date - 03/01/2023

Step	percent	Apprentice Base Wage	Health	Pension	Supplemental Unemployment	Total Rate
1	50	\$22.89	\$8.68	\$1.73	\$0.00	\$33.30
2	60	\$27.47	\$8.68	\$1.73	\$0.00	\$37.88
3	70	\$32.05	\$8.68	\$14.78	\$0.00	\$55.51
4	75	\$34.34	\$8.68	\$14.78	\$0.00	\$57.80
5	80	\$36.62	\$8.68	\$16.51	\$0.00	\$61.81
6	80	\$36.62	\$8.68	\$16.51	\$0.00	\$61.81
7	90	\$41.20	\$8.68	\$18.24	\$0.00	\$68.12
8	90	\$41.20	\$8.68	\$18.24	\$0.00	\$68.12

Notes:

% Indentured After 10/1/17; 45/45/55/55/70/70/80/80
Step 1&2 \$31.01/ 3&4 \$48.64/ 5&6 \$57.24/ 7&8 \$63.54

Apprentice to Journeyworker Ratio:1:5

CARPENTER WOOD FRAME <i>CARPENTERS-ZONE 3 (Wood Frame)</i>	04/01/2022	\$23.66	\$7.21	\$4.80	\$0.00	\$35.67
	04/01/2023	\$24.16	\$7.21	\$4.80	\$0.00	\$36.17

All Aspects of New Wood Frame Work

Classification

Effective Date Base Wage Health Pension Supplemental Unemployment Total Rate

Apprentice - CARPENTER (Wood Frame) - Zone 3

Effective Date - 04/01/2022

Step	percent	Apprentice Base Wage	Health	Pension	Supplemental Unemployment	Total Rate
1	60	\$14.20	\$7.21	\$0.00	\$0.00	\$21.41
2	60	\$14.20	\$7.21	\$0.00	\$0.00	\$21.41
3	65	\$15.38	\$7.21	\$0.00	\$0.00	\$22.59
4	70	\$16.56	\$7.21	\$0.00	\$0.00	\$23.77
5	75	\$17.75	\$7.21	\$3.80	\$0.00	\$28.76
6	80	\$18.93	\$7.21	\$3.80	\$0.00	\$29.94
7	85	\$20.11	\$7.21	\$3.80	\$0.00	\$31.12
8	90	\$21.29	\$7.21	\$3.80	\$0.00	\$32.30

Effective Date - 04/01/2023

Step	percent	Apprentice Base Wage	Health	Pension	Supplemental Unemployment	Total Rate
1	60	\$14.50	\$7.21	\$0.00	\$0.00	\$21.71
2	60	\$14.50	\$7.21	\$0.00	\$0.00	\$21.71
3	65	\$15.70	\$7.21	\$0.00	\$0.00	\$22.91
4	70	\$16.91	\$7.21	\$0.00	\$0.00	\$24.12
5	75	\$18.12	\$7.21	\$3.80	\$0.00	\$29.13
6	80	\$19.33	\$7.21	\$3.80	\$0.00	\$30.34
7	85	\$20.54	\$7.21	\$3.80	\$0.00	\$31.55
8	90	\$21.74	\$7.21	\$3.80	\$0.00	\$32.75

Notes:

% Indentured After 10/1/17; 45/45/55/55/70/70/80/80
 Step 1&2 \$17.86/ 3&4 \$20.22/ 5&6 \$27.57/ 7&8 \$29.94

Apprentice to Journeyworker Ratio:1:5

CEMENT MASONRY/PLASTERING BRICKLAYERS LOCAL 3 (LOWELL)	01/01/2020	\$45.23	\$12.75	\$22.41	\$0.62	\$81.01
---	------------	---------	---------	---------	--------	---------

Apprentice - CEMENT MASONRY/PLASTERING - Lowell

Effective Date - 01/01/2020

Step	percent	Apprentice Base Wage	Health	Pension	Supplemental Unemployment	Total Rate
1	50	\$22.62	\$12.75	\$15.41	\$0.00	\$50.78
2	60	\$27.14	\$12.75	\$17.41	\$0.62	\$57.92
3	65	\$29.40	\$12.75	\$18.41	\$0.62	\$61.18
4	70	\$31.66	\$12.75	\$19.41	\$0.62	\$64.44
5	75	\$33.92	\$12.75	\$20.41	\$0.62	\$67.70
6	80	\$36.18	\$12.75	\$21.41	\$0.62	\$70.96
7	90	\$40.71	\$12.75	\$22.41	\$0.62	\$76.49

Notes:

Steps 3,4 are 500 hrs. All other steps are 1,000 hrs.

Apprentice to Journeyworker Ratio:1:3

Classification	Effective Date	Base Wage	Health	Pension	Supplemental Unemployment	Total Rate
CHAIN SAW OPERATOR <i>LABORERS - ZONE 2</i>	06/01/2022	\$36.56	\$9.10	\$16.64	\$0.00	\$62.30
	12/01/2022	\$37.41	\$9.10	\$16.64	\$0.00	\$63.15
	06/01/2023	\$38.31	\$9.10	\$16.64	\$0.00	\$64.05
	12/01/2023	\$39.21	\$9.10	\$16.64	\$0.00	\$64.95
For apprentice rates see "Apprentice- LABORER"						
CLAM SHELLS/SLURRY BUCKETS/HEADING MACHINES <i>OPERATING ENGINEERS LOCAL 4</i>	06/01/2022	\$53.40	\$14.25	\$16.05	\$0.00	\$83.70
	12/01/2022	\$54.68	\$14.25	\$16.05	\$0.00	\$84.98
	06/01/2023	\$55.95	\$14.25	\$16.05	\$0.00	\$86.25
	12/01/2023	\$57.23	\$14.25	\$16.05	\$0.00	\$87.53
	06/01/2024	\$58.55	\$14.25	\$16.05	\$0.00	\$88.85
	12/01/2024	\$60.03	\$14.25	\$16.05	\$0.00	\$90.33
	06/01/2025	\$61.36	\$14.25	\$16.05	\$0.00	\$91.66
	12/01/2025	\$62.83	\$14.25	\$16.05	\$0.00	\$93.13
	06/01/2026	\$64.16	\$14.25	\$16.05	\$0.00	\$94.46
12/01/2026	\$65.64	\$14.25	\$16.05	\$0.00	\$95.94	
For apprentice rates see "Apprentice- OPERATING ENGINEERS"						
COMPRESSOR OPERATOR <i>OPERATING ENGINEERS LOCAL 4</i>	06/01/2022	\$34.26	\$14.25	\$16.05	\$0.00	\$64.56
	12/01/2022	\$35.08	\$14.25	\$16.05	\$0.00	\$65.38
	06/01/2023	\$35.90	\$14.25	\$16.05	\$0.00	\$66.20
	12/01/2023	\$36.72	\$14.25	\$16.05	\$0.00	\$67.02
	06/01/2024	\$37.57	\$14.25	\$16.05	\$0.00	\$67.87
	12/01/2024	\$38.52	\$14.25	\$16.05	\$0.00	\$68.82
	06/01/2025	\$39.37	\$14.25	\$16.05	\$0.00	\$69.67
	12/01/2025	\$40.32	\$14.25	\$16.05	\$0.00	\$70.62
	06/01/2026	\$41.18	\$14.25	\$16.05	\$0.00	\$71.48
12/01/2026	\$42.13	\$14.25	\$16.05	\$0.00	\$72.43	
For apprentice rates see "Apprentice- OPERATING ENGINEERS"						
DELEADER (BRIDGE) <i>PAINTERS LOCAL 35 - ZONE 2</i>	07/01/2022	\$54.86	\$8.65	\$23.05	\$0.00	\$86.56
	01/01/2023	\$56.06	\$8.65	\$23.05	\$0.00	\$87.76
	07/01/2023	\$57.26	\$8.65	\$23.05	\$0.00	\$88.96
	01/01/2024	\$58.46	\$8.65	\$23.05	\$0.00	\$90.16
	07/01/2024	\$59.66	\$8.65	\$23.05	\$0.00	\$91.36
	01/01/2025	\$60.86	\$8.65	\$23.05	\$0.00	\$92.56

Classification

Effective Date Base Wage Health Pension Supplemental Unemployment Total Rate

Apprentice - PAINTER Local 35 - BRIDGES/TANKS

Effective Date - 07/01/2022

Step	percent	Apprentice Base Wage	Health	Pension	Supplemental Unemployment	Total Rate
1	50	\$27.43	\$8.65	\$0.00	\$0.00	\$36.08
2	55	\$30.17	\$8.65	\$6.27	\$0.00	\$45.09
3	60	\$32.92	\$8.65	\$6.84	\$0.00	\$48.41
4	65	\$35.66	\$8.65	\$7.41	\$0.00	\$51.72
5	70	\$38.40	\$8.65	\$19.63	\$0.00	\$66.68
6	75	\$41.15	\$8.65	\$20.20	\$0.00	\$70.00
7	80	\$43.89	\$8.65	\$20.77	\$0.00	\$73.31
8	90	\$49.37	\$8.65	\$21.91	\$0.00	\$79.93

Effective Date - 01/01/2023

Step	percent	Apprentice Base Wage	Health	Pension	Supplemental Unemployment	Total Rate
1	50	\$28.03	\$8.65	\$0.00	\$0.00	\$36.68
2	55	\$30.83	\$8.65	\$6.27	\$0.00	\$45.75
3	60	\$33.64	\$8.65	\$6.84	\$0.00	\$49.13
4	65	\$36.44	\$8.65	\$7.41	\$0.00	\$52.50
5	70	\$39.24	\$8.65	\$19.63	\$0.00	\$67.52
6	75	\$42.05	\$8.65	\$20.20	\$0.00	\$70.90
7	80	\$44.85	\$8.65	\$20.77	\$0.00	\$74.27
8	90	\$50.45	\$8.65	\$21.91	\$0.00	\$81.01

Notes:

Steps are 750 hrs.

Apprentice to Journeyworker Ratio:1:1

DEMO: ADZEMAN LABORERS - ZONE 2	06/01/2022	\$42.33	\$9.10	\$17.57	\$0.00	\$69.00
	12/01/2022	\$43.33	\$9.10	\$17.57	\$0.00	\$70.00
	06/01/2023	\$44.33	\$9.10	\$17.57	\$0.00	\$71.00
	12/01/2023	\$45.58	\$9.10	\$17.57	\$0.00	\$72.25

For apprentice rates see "Apprentice- LABORER"

DEMO: BACKHOE/LOADER/HAMMER OPERATOR LABORERS - ZONE 2	06/01/2022	\$43.33	\$9.10	\$17.57	\$0.00	\$70.00
	12/01/2022	\$44.33	\$9.10	\$17.57	\$0.00	\$71.00
	06/01/2023	\$45.33	\$9.10	\$17.57	\$0.00	\$72.00
	12/01/2023	\$46.58	\$9.10	\$17.57	\$0.00	\$73.25

For apprentice rates see "Apprentice- LABORER"

DEMO: BURNERS LABORERS - ZONE 2	06/01/2022	\$43.08	\$9.10	\$17.57	\$0.00	\$69.75
	12/01/2022	\$44.08	\$9.10	\$17.57	\$0.00	\$70.75
	06/01/2023	\$45.08	\$9.10	\$17.57	\$0.00	\$71.75
	12/01/2023	\$46.33	\$9.10	\$17.57	\$0.00	\$73.00

For apprentice rates see "Apprentice- LABORER"

Classification	Effective Date	Base Wage	Health	Pension	Supplemental Unemployment	Total Rate
DEMO: CONCRETE CUTTER/SAWYER <i>LABORERS - ZONE 2</i>	06/01/2022	\$43.33	\$9.10	\$17.57	\$0.00	\$70.00
	12/01/2022	\$44.33	\$9.10	\$17.57	\$0.00	\$71.00
	06/01/2023	\$45.33	\$9.10	\$17.57	\$0.00	\$72.00
	12/01/2023	\$46.58	\$9.10	\$17.57	\$0.00	\$73.25
For apprentice rates see "Apprentice- LABORER"						
DEMO: JACKHAMMER OPERATOR <i>LABORERS - ZONE 2</i>	06/01/2022	\$43.08	\$9.10	\$17.57	\$0.00	\$69.75
	12/01/2022	\$44.08	\$9.10	\$17.57	\$0.00	\$70.75
	06/01/2023	\$45.08	\$9.10	\$17.57	\$0.00	\$71.75
	12/01/2023	\$46.33	\$9.10	\$17.57	\$0.00	\$73.00
For apprentice rates see "Apprentice- LABORER"						
DEMO: WRECKING LABORER <i>LABORERS - ZONE 2</i>	06/01/2022	\$42.33	\$9.10	\$17.57	\$0.00	\$69.00
	12/01/2022	\$43.33	\$9.10	\$17.57	\$0.00	\$70.00
	06/01/2023	\$44.33	\$9.10	\$17.57	\$0.00	\$71.00
	12/01/2023	\$45.58	\$9.10	\$17.57	\$0.00	\$72.25
For apprentice rates see "Apprentice- LABORER"						
DIRECTIONAL DRILL MACHINE OPERATOR <i>OPERATING ENGINEERS LOCAL 4</i>	06/01/2022	\$51.82	\$14.25	\$16.05	\$0.00	\$82.12
	12/01/2022	\$53.05	\$14.25	\$16.05	\$0.00	\$83.35
	06/01/2023	\$54.29	\$14.25	\$16.05	\$0.00	\$84.59
	12/01/2023	\$55.53	\$14.25	\$16.05	\$0.00	\$85.83
	06/01/2024	\$56.81	\$14.25	\$16.05	\$0.00	\$87.11
	12/01/2024	\$58.25	\$14.25	\$16.05	\$0.00	\$88.55
	06/01/2025	\$59.53	\$14.25	\$16.05	\$0.00	\$89.83
	12/01/2025	\$60.97	\$14.25	\$16.05	\$0.00	\$91.27
	06/01/2026	\$62.25	\$14.25	\$16.05	\$0.00	\$92.55
12/01/2026	\$63.69	\$14.25	\$16.05	\$0.00	\$93.99	
For apprentice rates see "Apprentice- OPERATING ENGINEERS"						
DIVER <i>PILE DRIVER LOCAL 56 (ZONE 1)</i>	08/01/2020	\$68.70	\$9.40	\$23.12	\$0.00	\$101.22
For apprentice rates see "Apprentice- PILE DRIVER"						
DIVER TENDER <i>PILE DRIVER LOCAL 56 (ZONE 1)</i>	08/01/2020	\$49.07	\$9.40	\$23.12	\$0.00	\$81.59
For apprentice rates see "Apprentice- PILE DRIVER"						
DIVER TENDER (EFFLUENT) <i>PILE DRIVER LOCAL 56 (ZONE 1)</i>	08/01/2020	\$73.60	\$9.40	\$23.12	\$0.00	\$106.12
For apprentice rates see "Apprentice- PILE DRIVER"						
DIVER/SLURRY (EFFLUENT) <i>PILE DRIVER LOCAL 56 (ZONE 1)</i>	08/01/2020	\$103.05	\$9.40	\$23.12	\$0.00	\$135.57
For apprentice rates see "Apprentice- PILE DRIVER"						
DRAWBRIDGE OPERATOR (Construction) <i>DRAWBRIDGE - SEIU LOCAL 888</i>	07/01/2020	\$26.77	\$6.67	\$3.93	\$0.16	\$37.53
ELECTRICIAN <i>ELECTRICIANS LOCAL 96</i>	09/04/2022	\$45.59	\$12.20	\$17.50	\$0.00	\$75.29

Apprentice - ELECTRICIAN - Local 96

Effective Date - 09/04/2022

Step	percent	Apprentice Base Wage	Health	Pension	Supplemental Unemployment	Total Rate
1	40	\$18.24	\$12.20	\$0.55	\$0.00	\$30.99
2	43	\$19.60	\$12.20	\$0.59	\$0.00	\$32.39
3	48	\$21.88	\$12.20	\$14.18	\$0.00	\$48.26
4	55	\$25.07	\$12.20	\$14.63	\$0.00	\$51.90
5	65	\$29.63	\$12.20	\$15.27	\$0.00	\$57.10
6	80	\$36.47	\$12.20	\$16.22	\$0.00	\$64.89

Notes:

Steps 1-2 are 1000 hrs; Steps 3-6 are 1500 hrs.

Apprentice to Journeyworker Ratio:2:3***

ELEVATOR CONSTRUCTOR ELEVATOR CONSTRUCTORS LOCAL 4	01/01/2022	\$65.62	\$16.03	\$20.21	\$0.00	\$101.86
---	------------	---------	---------	---------	--------	----------

Apprentice - ELEVATOR CONSTRUCTOR - Local 4

Effective Date - 01/01/2022

Step	percent	Apprentice Base Wage	Health	Pension	Supplemental Unemployment	Total Rate
1	50	\$32.81	\$16.03	\$0.00	\$0.00	\$48.84
2	55	\$36.09	\$16.03	\$20.21	\$0.00	\$72.33
3	65	\$42.65	\$16.03	\$20.21	\$0.00	\$78.89
4	70	\$45.93	\$16.03	\$20.21	\$0.00	\$82.17
5	80	\$52.50	\$16.03	\$20.21	\$0.00	\$88.74

Notes:

Steps 1-2 are 6 mos.; Steps 3-5 are 1 year

Apprentice to Journeyworker Ratio:1:1

ELEVATOR CONSTRUCTOR HELPER ELEVATOR CONSTRUCTORS LOCAL 4	01/01/2022	\$45.93	\$16.03	\$20.21	\$0.00	\$82.17
--	------------	---------	---------	---------	--------	---------

For apprentice rates see "Apprentice - ELEVATOR CONSTRUCTOR"

FENCE & GUARD RAIL ERECTOR (HEAVY & HIGHWAY) LABORERS - ZONE 2 (HEAVY & HIGHWAY)	12/01/2021	\$35.66	\$9.10	\$16.64	\$0.00	\$61.40
---	------------	---------	--------	---------	--------	---------

For apprentice rates see "Apprentice- LABORER (Heavy and Highway)"

FIELD ENG.INST.PERSON-BLDG,SITE,HVY/HWY OPERATING ENGINEERS LOCAL 4	05/01/2022	\$47.18	\$14.00	\$16.05	\$0.00	\$77.23
--	------------	---------	---------	---------	--------	---------

For apprentice rates see "Apprentice- OPERATING ENGINEERS"

FIELD ENG.PARTY CHIEF-BLDG,SITE,HVY/HWY OPERATING ENGINEERS LOCAL 4	05/01/2022	\$48.72	\$14.00	\$16.05	\$0.00	\$78.77
--	------------	---------	---------	---------	--------	---------

For apprentice rates see "Apprentice- OPERATING ENGINEERS"

FIELD ENG.ROD PERSON-BLDG,SITE,HVY/HWY OPERATING ENGINEERS LOCAL 4	05/01/2022	\$23.33	\$14.00	\$16.05	\$0.00	\$53.38
---	------------	---------	---------	---------	--------	---------

For apprentice rates see "Apprentice- OPERATING ENGINEERS"

FIRE ALARM INSTALLER ELECTRICIANS LOCAL 96	09/04/2022	\$45.59	\$12.20	\$17.50	\$0.00	\$75.29
---	------------	---------	---------	---------	--------	---------

Classification	Effective Date	Base Wage	Health	Pension	Supplemental Unemployment	Total Rate
For apprentice rates see "Apprentice- ELECTRICIAN"						
FIRE ALARM REPAIR / MAINT/COMMISSIONING <i>ELECTRICIANS LOCAL 96</i>	09/04/2022	\$45.59	\$12.20	\$17.50	\$0.00	\$75.29
For apprentice rates see "Apprentice- ELECTRICIAN"						
FIREMAN (ASST. ENGINEER) <i>OPERATING ENGINEERS LOCAL 4</i>	06/01/2022	\$42.53	\$14.25	\$16.05	\$0.00	\$72.83
	12/01/2022	\$43.54	\$14.25	\$16.05	\$0.00	\$73.84
	06/01/2023	\$44.56	\$14.25	\$16.05	\$0.00	\$74.86
	12/01/2023	\$45.57	\$14.25	\$16.05	\$0.00	\$75.87
	06/01/2024	\$46.63	\$14.25	\$16.05	\$0.00	\$76.93
	12/01/2024	\$47.81	\$14.25	\$16.05	\$0.00	\$78.11
	06/01/2025	\$48.87	\$14.25	\$16.05	\$0.00	\$79.17
	12/01/2025	\$50.04	\$14.25	\$16.05	\$0.00	\$80.34
	06/01/2026	\$51.10	\$14.25	\$16.05	\$0.00	\$81.40
	12/01/2026	\$52.28	\$14.25	\$16.05	\$0.00	\$82.58
For apprentice rates see "Apprentice- OPERATING ENGINEERS"						
FLAGGER & SIGNALER (HEAVY & HIGHWAY) <i>LABORERS - ZONE 2 (HEAVY & HIGHWAY)</i>	12/01/2021	\$24.50	\$9.10	\$16.64	\$0.00	\$50.24
For apprentice rates see "Apprentice- LABORER (Heavy and Highway)"						
FLOORCOVERER <i>FLOORCOVERERS LOCAL 2168 ZONE 1</i>	03/01/2022	\$49.93	\$8.68	\$20.27	\$0.00	\$78.88

Apprentice - FLOORCOVERER - Local 2168 Zone 1

Effective Date - 03/01/2022

Step	percent	Apprentice Base Wage	Health	Pension	Supplemental Unemployment	Total Rate
1	50	\$24.97	\$8.68	\$1.79	\$0.00	\$35.44
2	55	\$27.46	\$8.68	\$1.79	\$0.00	\$37.93
3	60	\$29.96	\$8.68	\$14.90	\$0.00	\$53.54
4	65	\$32.45	\$8.68	\$14.90	\$0.00	\$56.03
5	70	\$34.95	\$8.68	\$16.69	\$0.00	\$60.32
6	75	\$37.45	\$8.68	\$16.69	\$0.00	\$62.82
7	80	\$39.94	\$8.68	\$18.48	\$0.00	\$67.10
8	85	\$42.44	\$8.68	\$18.48	\$0.00	\$69.60

Notes: Steps are 750 hrs.
 % After 10/1/17; 45/45/55/55/70/70/80/80 (1500hr Steps)
 Step 1&2 \$32.94/ 3&4 \$39.66/ 5&6 \$60.32/ 7&8 \$67.10

Apprentice to Journeyworker Ratio:1:1

FORK LIFT/CHERRY PICKER <i>OPERATING ENGINEERS LOCAL 4</i>	06/01/2022	\$52.38	\$14.25	\$16.05	\$0.00	\$82.68
	12/01/2022	\$53.63	\$14.25	\$16.05	\$0.00	\$83.93
	06/01/2023	\$54.88	\$14.25	\$16.05	\$0.00	\$85.18
	12/01/2023	\$56.13	\$14.25	\$16.05	\$0.00	\$86.43
	06/01/2024	\$57.43	\$14.25	\$16.05	\$0.00	\$87.73
	12/01/2024	\$58.88	\$14.25	\$16.05	\$0.00	\$89.18
	06/01/2025	\$60.18	\$14.25	\$16.05	\$0.00	\$90.48
	12/01/2025	\$61.63	\$14.25	\$16.05	\$0.00	\$91.93
	06/01/2026	\$62.93	\$14.25	\$16.05	\$0.00	\$93.23
	12/01/2026	\$64.38	\$14.25	\$16.05	\$0.00	\$94.68

Classification	Effective Date	Base Wage	Health	Pension	Supplemental Unemployment	Total Rate
For apprentice rates see "Apprentice- OPERATING ENGINEERS"						
GENERATOR/LIGHTING PLANT/HEATERS <i>OPERATING ENGINEERS LOCAL 4</i>	06/01/2022	\$34.26	\$14.25	\$16.05	\$0.00	\$64.56
	12/01/2022	\$35.08	\$14.25	\$16.05	\$0.00	\$65.38
	06/01/2023	\$35.90	\$14.25	\$16.05	\$0.00	\$66.20
	12/01/2023	\$36.72	\$14.25	\$16.05	\$0.00	\$67.02
	06/01/2024	\$37.57	\$14.25	\$16.05	\$0.00	\$67.87
	12/01/2024	\$38.52	\$14.25	\$16.05	\$0.00	\$68.82
	06/01/2025	\$39.37	\$14.25	\$16.05	\$0.00	\$69.67
	12/01/2025	\$40.32	\$14.25	\$16.05	\$0.00	\$70.62
	06/01/2026	\$41.18	\$14.25	\$16.05	\$0.00	\$71.48
12/01/2026	\$42.13	\$14.25	\$16.05	\$0.00	\$72.43	

Classification	Effective Date	Base Wage	Health	Pension	Supplemental Unemployment	Total Rate
For apprentice rates see "Apprentice- OPERATING ENGINEERS"						
GLAZIER (GLASS PLANK/AIR BARRIER/INTERIOR SYSTEMS) <i>GLAZIERS LOCAL 35 (ZONE 2)</i>	07/01/2022	\$44.36	\$8.65	\$23.05	\$0.00	\$76.06
	01/01/2023	\$45.56	\$8.65	\$23.05	\$0.00	\$77.26
	07/01/2023	\$46.76	\$8.65	\$23.05	\$0.00	\$78.46
	01/01/2024	\$47.96	\$8.65	\$23.05	\$0.00	\$79.66
	07/01/2024	\$49.16	\$8.65	\$23.05	\$0.00	\$80.86
	01/01/2025	\$50.36	\$8.65	\$23.05	\$0.00	\$82.06

Apprentice - GLAZIER - Local 35 Zone 2

Effective Date - 07/01/2022

Step	percent	Apprentice Base Wage	Health	Pension	Supplemental Unemployment	Total Rate
1	50	\$22.18	\$8.65	\$0.00	\$0.00	\$30.83
2	55	\$24.40	\$8.65	\$6.27	\$0.00	\$39.32
3	60	\$26.62	\$8.65	\$6.84	\$0.00	\$42.11
4	65	\$28.83	\$8.65	\$7.41	\$0.00	\$44.89
5	70	\$31.05	\$8.65	\$19.63	\$0.00	\$59.33
6	75	\$33.27	\$8.65	\$20.20	\$0.00	\$62.12
7	80	\$35.49	\$8.65	\$20.77	\$0.00	\$64.91
8	90	\$39.92	\$8.65	\$21.91	\$0.00	\$70.48

Effective Date - 01/01/2023

Step	percent	Apprentice Base Wage	Health	Pension	Supplemental Unemployment	Total Rate
1	50	\$22.78	\$8.65	\$0.00	\$0.00	\$31.43
2	55	\$25.06	\$8.65	\$6.27	\$0.00	\$39.98
3	60	\$27.34	\$8.65	\$6.84	\$0.00	\$42.83
4	65	\$29.61	\$8.65	\$7.41	\$0.00	\$45.67
5	70	\$31.89	\$8.65	\$19.63	\$0.00	\$60.17
6	75	\$34.17	\$8.65	\$20.20	\$0.00	\$63.02
7	80	\$36.45	\$8.65	\$20.77	\$0.00	\$65.87
8	90	\$41.00	\$8.65	\$21.91	\$0.00	\$71.56

Notes:
Steps are 750 hrs.

Apprentice to Journeyworker Ratio:1:1

Classification	Effective Date	Base Wage	Health	Pension	Supplemental Unemployment	Total Rate
HOISTING ENGINEER/CRANES/GRADALLS <i>OPERATING ENGINEERS LOCAL 4</i>	06/01/2022	\$52.38	\$14.25	\$16.05	\$0.00	\$82.68
	12/01/2022	\$53.63	\$14.25	\$16.05	\$0.00	\$83.93
	06/01/2023	\$54.88	\$14.25	\$16.05	\$0.00	\$85.18
	12/01/2023	\$56.13	\$14.25	\$16.05	\$0.00	\$86.43
	06/01/2024	\$57.43	\$14.25	\$16.05	\$0.00	\$87.73
	12/01/2024	\$58.88	\$14.25	\$16.05	\$0.00	\$89.18
	06/01/2025	\$60.18	\$14.25	\$16.05	\$0.00	\$90.48
	12/01/2025	\$61.63	\$14.25	\$16.05	\$0.00	\$91.93
	06/01/2026	\$62.93	\$14.25	\$16.05	\$0.00	\$93.23
	12/01/2026	\$64.38	\$14.25	\$16.05	\$0.00	\$94.68

Apprentice - OPERATING ENGINEERS - Local 4

Effective Date - 06/01/2022

Step	percent	Apprentice Base Wage	Health	Pension	Supplemental Unemployment	Total Rate
1	55	\$28.81	\$14.00	\$0.00	\$0.00	\$42.81
2	60	\$31.43	\$14.00	\$16.05	\$0.00	\$61.48
3	65	\$34.05	\$14.00	\$16.05	\$0.00	\$64.10
4	70	\$36.67	\$14.00	\$16.05	\$0.00	\$66.72
5	75	\$39.29	\$14.00	\$16.05	\$0.00	\$69.34
6	80	\$41.90	\$14.00	\$16.05	\$0.00	\$71.95
7	85	\$44.52	\$14.00	\$16.05	\$0.00	\$74.57
8	90	\$47.14	\$14.00	\$16.05	\$0.00	\$77.19

Effective Date - 12/01/2022

Step	percent	Apprentice Base Wage	Health	Pension	Supplemental Unemployment	Total Rate
1	55	\$29.50	\$14.25	\$0.00	\$0.00	\$43.75
2	60	\$32.18	\$14.25	\$16.05	\$0.00	\$62.48
3	65	\$34.86	\$14.25	\$16.05	\$0.00	\$65.16
4	70	\$37.54	\$14.25	\$16.05	\$0.00	\$67.84
5	75	\$40.22	\$14.25	\$16.05	\$0.00	\$70.52
6	80	\$42.90	\$14.25	\$16.05	\$0.00	\$73.20
7	85	\$45.59	\$14.25	\$16.05	\$0.00	\$75.89
8	90	\$48.27	\$14.25	\$16.05	\$0.00	\$78.57

Notes:

Apprentice to Journeyworker Ratio:1:6

HVAC (DUCTWORK) <i>SHEETMETAL WORKERS LOCAL 17 - A</i>	02/01/2022	\$53.70	\$13.80	\$25.60	\$2.79	\$95.89
---	------------	---------	---------	---------	--------	---------

For apprentice rates see "Apprentice- SHEET METAL WORKER"

HVAC (ELECTRICAL CONTROLS) <i>ELECTRICIANS LOCAL 96</i>	09/04/2022	\$45.59	\$12.20	\$17.50	\$0.00	\$75.29
--	------------	---------	---------	---------	--------	---------

For apprentice rates see "Apprentice- ELECTRICIAN"

HVAC (TESTING AND BALANCING - AIR) <i>SHEETMETAL WORKERS LOCAL 17 - A</i>	02/01/2022	\$53.70	\$13.80	\$25.60	\$2.79	\$95.89
--	------------	---------	---------	---------	--------	---------

For apprentice rates see "Apprentice- SHEET METAL WORKER"

Classification	Effective Date	Base Wage	Health	Pension	Supplemental Unemployment	Total Rate
HVAC (TESTING AND BALANCING -WATER) <i>PIPEFITTERS LOCAL 537</i>	03/01/2021	\$57.94	\$11.70	\$20.24	\$0.00	\$89.88
For apprentice rates see "Apprentice- PIPEFITTER" or "PLUMBER/PIPEFITTER"						
HVAC MECHANIC <i>PIPEFITTERS LOCAL 537</i>	03/01/2021	\$57.94	\$11.70	\$20.24	\$0.00	\$89.88
For apprentice rates see "Apprentice- PIPEFITTER" or "PLUMBER/PIPEFITTER"						
HYDRAULIC DRILLS <i>LABORERS - ZONE 2</i>	06/01/2022	\$37.06	\$9.10	\$16.64	\$0.00	\$62.80
	12/01/2022	\$37.91	\$9.10	\$16.64	\$0.00	\$63.65
	06/01/2023	\$38.81	\$9.10	\$16.64	\$0.00	\$64.55
	12/01/2023	\$39.71	\$9.10	\$16.64	\$0.00	\$65.45
For apprentice rates see "Apprentice- LABORER"						
HYDRAULIC DRILLS (HEAVY & HIGHWAY) <i>LABORERS - ZONE 2 (HEAVY & HIGHWAY)</i>	12/01/2021	\$36.16	\$9.10	\$16.64	\$0.00	\$61.90
For apprentice rates see "Apprentice- LABORER (Heavy and Highway)"						
INSULATOR (PIPES & TANKS) <i>HEAT & FROST INSULATORS LOCAL 6 (BOSTON)</i>	09/01/2022	\$53.85	\$13.80	\$17.14	\$0.00	\$84.79

Apprentice - ASBESTOS INSULATOR (Pipes & Tanks) - Local 6 Boston

Effective Date - 09/01/2022

Step	percent	Apprentice Base Wage	Health	Pension	Supplemental Unemployment	Total Rate
1	50	\$26.93	\$13.80	\$12.42	\$0.00	\$53.15
2	60	\$32.31	\$13.80	\$13.36	\$0.00	\$59.47
3	70	\$37.70	\$13.80	\$14.31	\$0.00	\$65.81
4	80	\$43.08	\$13.80	\$15.25	\$0.00	\$72.13

Notes:

Steps are 1 year

Apprentice to Journeyworker Ratio:1:4

IRONWORKER/WELDER <i>IRONWORKERS LOCAL 7 (WORCESTER AREA)</i>	09/16/2022	\$51.29	\$8.25	\$26.70	\$0.00	\$86.24
--	------------	---------	--------	---------	--------	---------

Apprentice - IRONWORKER - Local 7 Worcester

Effective Date - 09/16/2022

Step	percent	Apprentice Base Wage	Health	Pension	Supplemental Unemployment	Total Rate
1	60	\$30.77	\$8.25	\$26.70	\$0.00	\$65.72
2	70	\$35.90	\$8.25	\$26.70	\$0.00	\$70.85
3	75	\$38.47	\$8.25	\$26.70	\$0.00	\$73.42
4	80	\$41.03	\$8.25	\$26.70	\$0.00	\$75.98
5	85	\$43.60	\$8.25	\$26.70	\$0.00	\$78.55
6	90	\$46.16	\$8.25	\$26.70	\$0.00	\$81.11

Notes:

Apprentice to Journeyworker Ratio:1:4

Classification	Effective Date	Base Wage	Health	Pension	Supplemental Unemployment	Total Rate
JACKHAMMER & PAVING BREAKER OPERATOR <i>LABORERS - ZONE 2</i>	06/01/2022	\$36.56	\$9.10	\$16.64	\$0.00	\$62.30
	12/01/2022	\$37.41	\$9.10	\$16.64	\$0.00	\$63.15
	06/01/2023	\$38.31	\$9.10	\$16.64	\$0.00	\$64.05
	12/01/2023	\$39.21	\$9.10	\$16.64	\$0.00	\$64.95

For apprentice rates see "Apprentice- LABORER"

LABORER <i>LABORERS - ZONE 2</i>	06/01/2022	\$36.31	\$9.10	\$16.64	\$0.00	\$62.05
	12/01/2022	\$37.16	\$9.10	\$16.64	\$0.00	\$62.90
	06/01/2023	\$38.06	\$9.10	\$16.64	\$0.00	\$63.80
	12/01/2023	\$38.96	\$9.10	\$16.64	\$0.00	\$64.70

Apprentice - LABORER - Zone 2

Effective Date - 06/01/2022

Step	percent	Apprentice Base Wage	Health	Pension	Supplemental Unemployment	Total Rate
1	60	\$21.79	\$9.10	\$16.64	\$0.00	\$47.53
2	70	\$25.42	\$9.10	\$16.64	\$0.00	\$51.16
3	80	\$29.05	\$9.10	\$16.64	\$0.00	\$54.79
4	90	\$32.68	\$9.10	\$16.64	\$0.00	\$58.42

Effective Date - 12/01/2022

Step	percent	Apprentice Base Wage	Health	Pension	Supplemental Unemployment	Total Rate
1	60	\$22.30	\$9.10	\$16.64	\$0.00	\$48.04
2	70	\$26.01	\$9.10	\$16.64	\$0.00	\$51.75
3	80	\$29.73	\$9.10	\$16.64	\$0.00	\$55.47
4	90	\$33.44	\$9.10	\$16.64	\$0.00	\$59.18

Notes:

Apprentice to Journeyworker Ratio:1:5

LABORER (HEAVY & HIGHWAY) <i>LABORERS - ZONE 2 (HEAVY & HIGHWAY)</i>	12/01/2021	\$35.41	\$9.10	\$16.64	\$0.00	\$61.15
---	------------	---------	--------	---------	--------	---------

Apprentice - LABORER (Heavy & Highway) - Zone 2

Effective Date - 12/01/2021

Step	percent	Apprentice Base Wage	Health	Pension	Supplemental Unemployment	Total Rate
1	60	\$21.25	\$9.10	\$16.64	\$0.00	\$46.99
2	70	\$24.79	\$9.10	\$16.64	\$0.00	\$50.53
3	80	\$28.33	\$9.10	\$16.64	\$0.00	\$54.07
4	90	\$31.87	\$9.10	\$16.64	\$0.00	\$57.61

Notes:

Apprentice to Journeyworker Ratio:1:5

Classification	Effective Date	Base Wage	Health	Pension	Supplemental Unemployment	Total Rate
LABORER: CARPENTER TENDER <i>LABORERS - ZONE 2</i>	06/01/2022	\$36.31	\$9.10	\$16.64	\$0.00	\$62.05
	12/01/2022	\$37.16	\$9.10	\$16.64	\$0.00	\$62.90
	06/01/2023	\$38.06	\$9.10	\$16.64	\$0.00	\$63.80
	12/01/2023	\$38.96	\$9.10	\$16.64	\$0.00	\$64.70
For apprentice rates see "Apprentice- LABORER"						
LABORER: CEMENT FINISHER TENDER <i>LABORERS - ZONE 2</i>	06/01/2022	\$36.31	\$9.10	\$16.64	\$0.00	\$62.05
	12/01/2022	\$37.16	\$9.10	\$16.64	\$0.00	\$62.90
	06/01/2023	\$38.06	\$9.10	\$16.64	\$0.00	\$63.80
	12/01/2023	\$38.96	\$9.10	\$16.64	\$0.00	\$64.70
For apprentice rates see "Apprentice- LABORER"						
LABORER: HAZARDOUS WASTE/ASBESTOS REMOVER <i>LABORERS - ZONE 2</i>	06/01/2022	\$36.40	\$9.10	\$16.70	\$0.00	\$62.20
	12/01/2022	\$37.25	\$9.10	\$16.70	\$0.00	\$63.05
	06/01/2023	\$38.15	\$9.10	\$16.70	\$0.00	\$63.95
	12/01/2023	\$39.05	\$9.10	\$16.70	\$0.00	\$64.85
For apprentice rates see "Apprentice- LABORER"						
LABORER: MASON TENDER <i>LABORERS - ZONE 2</i>	06/01/2022	\$36.56	\$9.10	\$16.64	\$0.00	\$62.30
	12/01/2022	\$37.41	\$9.10	\$16.64	\$0.00	\$63.15
	06/01/2023	\$38.31	\$9.10	\$16.64	\$0.00	\$64.05
	12/01/2023	\$39.21	\$9.10	\$16.64	\$0.00	\$64.95
For apprentice rates see "Apprentice- LABORER"						
LABORER: MASON TENDER (HEAVY & HIGHWAY) <i>LABORERS - ZONE 2 (HEAVY & HIGHWAY)</i>	12/01/2021	\$35.66	\$9.10	\$16.64	\$0.00	\$61.40
For apprentice rates see "Apprentice- LABORER (Heavy and Highway)"						
LABORER: MULTI-TRADE TENDER <i>LABORERS - ZONE 2</i>	06/01/2022	\$36.31	\$9.10	\$16.64	\$0.00	\$62.05
	12/01/2022	\$37.16	\$9.10	\$16.64	\$0.00	\$62.90
	06/01/2023	\$38.06	\$9.10	\$16.64	\$0.00	\$63.80
	12/01/2023	\$38.96	\$9.10	\$16.64	\$0.00	\$64.70
For apprentice rates see "Apprentice- LABORER"						
LABORER: TREE REMOVER <i>LABORERS - ZONE 2</i>	06/01/2022	\$36.31	\$9.10	\$16.64	\$0.00	\$62.05
	12/01/2022	\$37.16	\$9.10	\$16.64	\$0.00	\$62.90
	06/01/2023	\$38.06	\$9.10	\$16.64	\$0.00	\$63.80
	12/01/2023	\$38.96	\$9.10	\$16.64	\$0.00	\$64.70
This classification applies to the removal of standing trees, and the trimming and removal of branches and limbs when related to public works construction or site clearance incidental to construction . For apprentice rates see "Apprentice- LABORER"						
LASER BEAM OPERATOR <i>LABORERS - ZONE 2</i>	06/01/2022	\$36.56	\$9.10	\$16.64	\$0.00	\$62.30
	12/01/2022	\$37.41	\$9.10	\$16.64	\$0.00	\$63.15
	06/01/2023	\$38.31	\$9.10	\$16.64	\$0.00	\$64.05
	12/01/2023	\$39.21	\$9.10	\$16.64	\$0.00	\$64.95
For apprentice rates see "Apprentice- LABORER"						
LASER BEAM OPERATOR (HEAVY & HIGHWAY) <i>LABORERS - ZONE 2 (HEAVY & HIGHWAY)</i>	12/01/2021	\$35.66	\$9.10	\$16.64	\$0.00	\$61.40
For apprentice rates see "Apprentice- LABORER (Heavy and Highway)"						

Classification	Effective Date	Base Wage	Health	Pension	Supplemental Unemployment	Total Rate
MARBLE & TILE FINISHERS BRICKLAYERS LOCAL 3 - MARBLE & TILE	08/01/2022	\$45.29	\$11.49	\$20.37	\$0.00	\$77.15
	02/01/2023	\$46.25	\$11.49	\$20.37	\$0.00	\$78.11
	08/01/2023	\$47.89	\$11.49	\$20.37	\$0.00	\$79.75
	02/01/2024	\$48.89	\$11.49	\$20.37	\$0.00	\$80.75
	08/01/2024	\$50.57	\$11.49	\$20.37	\$0.00	\$82.43
	02/01/2025	\$51.61	\$11.49	\$20.37	\$0.00	\$83.47
	08/01/2025	\$53.33	\$11.49	\$20.37	\$0.00	\$85.19
	02/01/2026	\$54.41	\$11.49	\$20.37	\$0.00	\$86.27
	08/01/2026	\$56.17	\$11.49	\$20.37	\$0.00	\$88.03
	02/01/2027	\$57.29	\$11.49	\$20.37	\$0.00	\$89.15

Apprentice - MARBLE & TILE FINISHER - Local 3 Marble & Tile

Effective Date - 08/01/2022

Step	percent	Apprentice Base Wage	Health	Pension	Supplemental Unemployment	Total Rate
1	50	\$22.65	\$11.49	\$20.37	\$0.00	\$54.51
2	60	\$27.17	\$11.49	\$20.37	\$0.00	\$59.03
3	70	\$31.70	\$11.49	\$20.37	\$0.00	\$63.56
4	80	\$36.23	\$11.49	\$20.37	\$0.00	\$68.09
5	90	\$40.76	\$11.49	\$20.37	\$0.00	\$72.62

Effective Date - 02/01/2023

Step	percent	Apprentice Base Wage	Health	Pension	Supplemental Unemployment	Total Rate
1	50	\$23.13	\$11.49	\$20.37	\$0.00	\$54.99
2	60	\$27.75	\$11.49	\$20.37	\$0.00	\$59.61
3	70	\$32.38	\$11.49	\$20.37	\$0.00	\$64.24
4	80	\$37.00	\$11.49	\$20.37	\$0.00	\$68.86
5	90	\$41.63	\$11.49	\$20.37	\$0.00	\$73.49

Notes:

Apprentice to Journeyworker Ratio:1:3

MARBLE MASONS, TILELAYERS & TERRAZZO MECH BRICKLAYERS LOCAL 3 - MARBLE & TILE	08/01/2022	\$59.17	\$11.49	\$22.31	\$0.00	\$92.97
	02/01/2023	\$60.37	\$11.49	\$22.31	\$0.00	\$94.17
	08/01/2023	\$62.42	\$11.49	\$22.31	\$0.00	\$96.22
	02/01/2024	\$63.67	\$11.49	\$22.31	\$0.00	\$97.47
	08/01/2024	\$65.77	\$11.49	\$22.31	\$0.00	\$99.57
	02/01/2025	\$67.07	\$11.49	\$22.31	\$0.00	\$100.87
	08/01/2025	\$69.22	\$11.49	\$22.31	\$0.00	\$103.02
	02/01/2026	\$70.57	\$11.49	\$22.31	\$0.00	\$104.37
	08/01/2026	\$72.77	\$11.49	\$22.31	\$0.00	\$106.57
	02/01/2027	\$74.17	\$11.49	\$22.31	\$0.00	\$107.97

Classification

Effective Date Base Wage Health Pension Supplemental Unemployment Total Rate

Apprentice - MARBLE-TILE-TERRAZZO MECHANIC - Local 3 Marble & Tile

Effective Date - 08/01/2022

Step	percent	Apprentice Base Wage	Health	Pension	Supplemental Unemployment	Total Rate
1	50	\$29.59	\$11.49	\$22.31	\$0.00	\$63.39
2	60	\$35.50	\$11.49	\$22.31	\$0.00	\$69.30
3	70	\$41.42	\$11.49	\$22.31	\$0.00	\$75.22
4	80	\$47.34	\$11.49	\$22.31	\$0.00	\$81.14
5	90	\$53.25	\$11.49	\$22.31	\$0.00	\$87.05

Effective Date - 02/01/2023

Step	percent	Apprentice Base Wage	Health	Pension	Supplemental Unemployment	Total Rate
1	50	\$30.19	\$11.49	\$22.31	\$0.00	\$63.99
2	60	\$36.22	\$11.49	\$22.31	\$0.00	\$70.02
3	70	\$42.26	\$11.49	\$22.31	\$0.00	\$76.06
4	80	\$48.30	\$11.49	\$22.31	\$0.00	\$82.10
5	90	\$54.33	\$11.49	\$22.31	\$0.00	\$88.13

Notes:

Apprentice to Journeyworker Ratio:1:5

MECH. SWEEPER OPERATOR (ON CONST. SITES) <i>OPERATING ENGINEERS LOCAL 4</i>	06/01/2022	\$51.82	\$14.25	\$16.05	\$0.00	\$82.12
	12/01/2022	\$53.05	\$14.25	\$16.05	\$0.00	\$83.35
	06/01/2023	\$54.29	\$14.25	\$16.05	\$0.00	\$84.59
	12/01/2023	\$55.53	\$14.25	\$16.05	\$0.00	\$85.83
	06/01/2024	\$56.81	\$14.25	\$16.05	\$0.00	\$87.11
	12/01/2024	\$58.25	\$14.25	\$16.05	\$0.00	\$88.55
	06/01/2025	\$59.53	\$14.25	\$16.05	\$0.00	\$89.83
	12/01/2025	\$60.97	\$14.25	\$16.05	\$0.00	\$91.27
	06/01/2026	\$62.25	\$14.25	\$16.05	\$0.00	\$92.55
	12/01/2026	\$63.69	\$14.25	\$16.05	\$0.00	\$93.99

For apprentice rates see "Apprentice- OPERATING ENGINEERS"

MECHANICS MAINTENANCE <i>OPERATING ENGINEERS LOCAL 4</i>	06/01/2022	\$51.82	\$14.25	\$16.05	\$0.00	\$82.12
	12/01/2022	\$53.05	\$14.25	\$16.05	\$0.00	\$83.35
	06/01/2023	\$54.29	\$14.25	\$16.05	\$0.00	\$84.59
	12/01/2023	\$55.53	\$14.25	\$16.05	\$0.00	\$85.83
	06/01/2024	\$56.81	\$14.25	\$16.05	\$0.00	\$87.11
	12/01/2024	\$58.25	\$14.25	\$16.05	\$0.00	\$88.55
	06/01/2025	\$59.53	\$14.25	\$16.05	\$0.00	\$89.83
	12/01/2025	\$60.97	\$14.25	\$16.05	\$0.00	\$91.27
	06/01/2026	\$62.25	\$14.25	\$16.05	\$0.00	\$92.55
	12/01/2026	\$63.69	\$14.25	\$16.05	\$0.00	\$93.99

For apprentice rates see "Apprentice- OPERATING ENGINEERS"

MILLWRIGHT (Zone 2) <i>MILLWRIGHTS LOCAL 1121 - Zone 2</i>	01/03/2022	\$40.67	\$8.58	\$21.57	\$0.00	\$70.82
	01/02/2023	\$41.92	\$8.58	\$21.57	\$0.00	\$72.07

Apprentice - MILLWRIGHT - Local 1121 Zone 2

Effective Date - 01/03/2022

Step	percent	Apprentice Base Wage	Health	Pension	Supplemental Unemployment	Total Rate
1	55	\$22.37	\$8.58	\$5.72	\$0.00	\$36.67
2	65	\$26.44	\$8.58	\$17.93	\$0.00	\$52.95
3	75	\$30.50	\$8.58	\$18.98	\$0.00	\$58.06
4	85	\$34.57	\$8.58	\$20.01	\$0.00	\$63.16

Effective Date - 01/02/2023

Step	percent	Apprentice Base Wage	Health	Pension	Supplemental Unemployment	Total Rate
1	55	\$23.06	\$8.58	\$5.72	\$0.00	\$37.36
2	65	\$27.25	\$8.58	\$17.93	\$0.00	\$53.76
3	75	\$31.44	\$8.58	\$18.98	\$0.00	\$59.00
4	85	\$35.63	\$8.58	\$20.01	\$0.00	\$64.22

Notes: Step 1&2 Appr. indentured after 1/6/2020 receive no pension, but do receive annuity. (Step 1 \$5.72, Step 2 \$6.66)
Steps are 2,000 hours

Apprentice to Journeyworker Ratio:1:4

MORTAR MIXER <i>LABORERS - ZONE 2</i>	06/01/2022	\$36.56	\$9.10	\$16.64	\$0.00	\$62.30
	12/01/2022	\$37.41	\$9.10	\$16.64	\$0.00	\$63.15
	06/01/2023	\$38.31	\$9.10	\$16.64	\$0.00	\$64.05
	12/01/2023	\$39.21	\$9.10	\$16.64	\$0.00	\$64.95

For apprentice rates see "Apprentice- LABORER"

OILER (OTHER THAN TRUCK CRANES,GRADALLS) <i>OPERATING ENGINEERS LOCAL 4</i>	06/01/2022	\$23.80	\$14.25	\$16.05	\$0.00	\$54.10
	12/01/2022	\$24.37	\$14.25	\$16.05	\$0.00	\$54.67
	06/01/2023	\$24.94	\$14.25	\$16.05	\$0.00	\$55.24
	12/01/2023	\$25.51	\$14.25	\$16.05	\$0.00	\$55.81
	06/01/2024	\$26.11	\$14.25	\$16.05	\$0.00	\$56.41
	12/01/2024	\$26.77	\$14.25	\$16.05	\$0.00	\$57.07
	06/01/2025	\$27.37	\$14.25	\$16.05	\$0.00	\$57.67
	12/01/2025	\$28.03	\$14.25	\$16.05	\$0.00	\$58.33
	06/01/2026	\$28.62	\$14.25	\$16.05	\$0.00	\$58.92
	12/01/2026	\$29.29	\$14.25	\$16.05	\$0.00	\$59.59

For apprentice rates see "Apprentice- OPERATING ENGINEERS"

OILER (TRUCK CRANES, GRADALLS) <i>OPERATING ENGINEERS LOCAL 4</i>	06/01/2022	\$28.88	\$14.25	\$16.05	\$0.00	\$59.18
	12/01/2022	\$29.57	\$14.25	\$16.05	\$0.00	\$59.87
	06/01/2023	\$30.27	\$14.25	\$16.05	\$0.00	\$60.57
	12/01/2023	\$30.96	\$14.25	\$16.05	\$0.00	\$61.26
	06/01/2024	\$31.68	\$14.25	\$16.05	\$0.00	\$61.98
	12/01/2024	\$32.48	\$14.25	\$16.05	\$0.00	\$62.78
	06/01/2025	\$33.20	\$14.25	\$16.05	\$0.00	\$63.50
	12/01/2025	\$34.00	\$14.25	\$16.05	\$0.00	\$64.30
	06/01/2026	\$34.72	\$14.25	\$16.05	\$0.00	\$65.02
	12/01/2026	\$35.52	\$14.25	\$16.05	\$0.00	\$65.82

Classification	Effective Date	Base Wage	Health	Pension	Supplemental Unemployment	Total Rate
For apprentice rates see "Apprentice- OPERATING ENGINEERS"						
OTHER POWER DRIVEN EQUIPMENT - CLASS II <i>OPERATING ENGINEERS LOCAL 4</i>	06/01/2022	\$51.82	\$14.25	\$16.05	\$0.00	\$82.12
	12/01/2022	\$53.05	\$14.25	\$16.05	\$0.00	\$83.35
	06/01/2023	\$54.29	\$14.25	\$16.05	\$0.00	\$84.59
	12/01/2023	\$55.53	\$14.25	\$16.05	\$0.00	\$85.83
	06/01/2024	\$56.81	\$14.25	\$16.05	\$0.00	\$87.11
	12/01/2024	\$58.25	\$14.25	\$16.05	\$0.00	\$88.55
	06/01/2025	\$59.53	\$14.25	\$16.05	\$0.00	\$89.83
	12/01/2025	\$60.97	\$14.25	\$16.05	\$0.00	\$91.27
	06/01/2026	\$62.25	\$14.25	\$16.05	\$0.00	\$92.55
	12/01/2026	\$63.69	\$14.25	\$16.05	\$0.00	\$93.99

Classification	Effective Date	Base Wage	Health	Pension	Supplemental Unemployment	Total Rate
For apprentice rates see "Apprentice- OPERATING ENGINEERS"						
PAINTER (BRIDGES/TANKS) <i>PAINTERS LOCAL 35 - ZONE 2</i>	07/01/2022	\$54.86	\$8.65	\$23.05	\$0.00	\$86.56
	01/01/2023	\$56.06	\$8.65	\$23.05	\$0.00	\$87.76
	07/01/2023	\$57.26	\$8.65	\$23.05	\$0.00	\$88.96
	01/01/2024	\$58.46	\$8.65	\$23.05	\$0.00	\$90.16
	07/01/2024	\$59.66	\$8.65	\$23.05	\$0.00	\$91.36
	01/01/2025	\$60.86	\$8.65	\$23.05	\$0.00	\$92.56

Apprentice - PAINTER Local 35 - BRIDGES/TANKS

Effective Date - 07/01/2022

Step	percent	Apprentice Base Wage	Health	Pension	Supplemental Unemployment	Total Rate
1	50	\$27.43	\$8.65	\$0.00	\$0.00	\$36.08
2	55	\$30.17	\$8.65	\$6.27	\$0.00	\$45.09
3	60	\$32.92	\$8.65	\$6.84	\$0.00	\$48.41
4	65	\$35.66	\$8.65	\$7.41	\$0.00	\$51.72
5	70	\$38.40	\$8.65	\$19.63	\$0.00	\$66.68
6	75	\$41.15	\$8.65	\$20.20	\$0.00	\$70.00
7	80	\$43.89	\$8.65	\$20.77	\$0.00	\$73.31
8	90	\$49.37	\$8.65	\$21.91	\$0.00	\$79.93

Effective Date - 01/01/2023

Step	percent	Apprentice Base Wage	Health	Pension	Supplemental Unemployment	Total Rate
1	50	\$28.03	\$8.65	\$0.00	\$0.00	\$36.68
2	55	\$30.83	\$8.65	\$6.27	\$0.00	\$45.75
3	60	\$33.64	\$8.65	\$6.84	\$0.00	\$49.13
4	65	\$36.44	\$8.65	\$7.41	\$0.00	\$52.50
5	70	\$39.24	\$8.65	\$19.63	\$0.00	\$67.52
6	75	\$42.05	\$8.65	\$20.20	\$0.00	\$70.90
7	80	\$44.85	\$8.65	\$20.77	\$0.00	\$74.27
8	90	\$50.45	\$8.65	\$21.91	\$0.00	\$81.01

Notes:

Steps are 750 hrs.

Apprentice to Journeyworker Ratio:1:1

Classification	Effective Date	Base Wage	Health	Pension	Supplemental Unemployment	Total Rate
PAINTER (SPRAY OR SANDBLAST, NEW) * * If 30% or more of surfaces to be painted are new construction, NEW paint rate shall be used. <i>PAINTERS LOCAL 35 - ZONE 2</i>	07/01/2022	\$45.76	\$8.65	\$23.05	\$0.00	\$77.46
	01/01/2023	\$46.96	\$8.65	\$23.05	\$0.00	\$78.66
	07/01/2023	\$48.16	\$8.65	\$23.05	\$0.00	\$79.86
	01/01/2024	\$49.36	\$8.65	\$23.05	\$0.00	\$81.06
	07/01/2024	\$50.56	\$8.65	\$23.05	\$0.00	\$82.26
	01/01/2025	\$51.76	\$8.65	\$23.05	\$0.00	\$83.46

Apprentice - PAINTER Local 35 Zone 2 - Spray/Sandblast - New

Effective Date - 07/01/2022

Step	percent	Apprentice Base Wage	Health	Pension	Supplemental Unemployment	Total Rate
1	50	\$22.88	\$8.65	\$0.00	\$0.00	\$31.53
2	55	\$25.17	\$8.65	\$6.27	\$0.00	\$40.09
3	60	\$27.46	\$8.65	\$6.84	\$0.00	\$42.95
4	65	\$29.74	\$8.65	\$7.41	\$0.00	\$45.80
5	70	\$32.03	\$8.65	\$19.63	\$0.00	\$60.31
6	75	\$34.32	\$8.65	\$20.20	\$0.00	\$63.17
7	80	\$36.61	\$8.65	\$20.77	\$0.00	\$66.03
8	90	\$41.18	\$8.65	\$21.91	\$0.00	\$71.74

Effective Date - 01/01/2023

Step	percent	Apprentice Base Wage	Health	Pension	Supplemental Unemployment	Total Rate
1	50	\$23.48	\$8.65	\$0.00	\$0.00	\$32.13
2	55	\$25.83	\$8.65	\$6.27	\$0.00	\$40.75
3	60	\$28.18	\$8.65	\$6.84	\$0.00	\$43.67
4	65	\$30.52	\$8.65	\$7.41	\$0.00	\$46.58
5	70	\$32.87	\$8.65	\$19.63	\$0.00	\$61.15
6	75	\$35.22	\$8.65	\$20.20	\$0.00	\$64.07
7	80	\$37.57	\$8.65	\$20.77	\$0.00	\$66.99
8	90	\$42.26	\$8.65	\$21.91	\$0.00	\$72.82

Notes:

Steps are 750 hrs.

Apprentice to Journeyworker Ratio:1:1

PAINTER (SPRAY OR SANDBLAST, REPAINT) <i>PAINTERS LOCAL 35 - ZONE 2</i>	07/01/2022	\$43.82	\$8.65	\$23.05	\$0.00	\$75.52
	01/01/2023	\$45.02	\$8.65	\$23.05	\$0.00	\$76.72
	07/01/2023	\$46.22	\$8.65	\$23.05	\$0.00	\$77.92
	01/01/2024	\$47.42	\$8.65	\$23.05	\$0.00	\$79.12
	07/01/2024	\$48.62	\$8.65	\$23.05	\$0.00	\$80.32
	01/01/2025	\$49.82	\$8.65	\$23.05	\$0.00	\$81.52

Classification

Effective Date Base Wage Health Pension Supplemental Unemployment Total Rate

Apprentice - PAINTER Local 35 Zone 2 - Spray/Sandblast - Repaint

Effective Date - 07/01/2022

Step	percent	Apprentice Base Wage	Health	Pension	Supplemental Unemployment	Total Rate
1	50	\$21.91	\$8.65	\$0.00	\$0.00	\$30.56
2	55	\$24.10	\$8.65	\$6.27	\$0.00	\$39.02
3	60	\$26.29	\$8.65	\$6.84	\$0.00	\$41.78
4	65	\$28.48	\$8.65	\$7.41	\$0.00	\$44.54
5	70	\$30.67	\$8.65	\$19.63	\$0.00	\$58.95
6	75	\$32.87	\$8.65	\$20.20	\$0.00	\$61.72
7	80	\$35.06	\$8.65	\$20.77	\$0.00	\$64.48
8	90	\$39.44	\$8.65	\$21.91	\$0.00	\$70.00

Effective Date - 01/01/2023

Step	percent	Apprentice Base Wage	Health	Pension	Supplemental Unemployment	Total Rate
1	50	\$22.51	\$8.65	\$0.00	\$0.00	\$31.16
2	55	\$24.76	\$8.65	\$6.27	\$0.00	\$39.68
3	60	\$27.01	\$8.65	\$6.84	\$0.00	\$42.50
4	65	\$29.26	\$8.65	\$7.41	\$0.00	\$45.32
5	70	\$31.51	\$8.65	\$19.63	\$0.00	\$59.79
6	75	\$33.77	\$8.65	\$20.20	\$0.00	\$62.62
7	80	\$36.02	\$8.65	\$20.77	\$0.00	\$65.44
8	90	\$40.52	\$8.65	\$21.91	\$0.00	\$71.08

Notes:

Steps are 750 hrs.

Apprentice to Journeyworker Ratio:1:1

PAINTER / TAPER (BRUSH, NEW) *	07/01/2022	\$44.36	\$8.65	\$23.05	\$0.00	\$76.06
* If 30% or more of surfaces to be painted are new construction, NEW paint rate shall be used. PAINTERS LOCAL 35 - ZONE 2	01/01/2023	\$45.56	\$8.65	\$23.05	\$0.00	\$77.26
	07/01/2023	\$46.76	\$8.65	\$23.05	\$0.00	\$78.46
	01/01/2024	\$47.96	\$8.65	\$23.05	\$0.00	\$79.66
	07/01/2024	\$49.16	\$8.65	\$23.05	\$0.00	\$80.86
	01/01/2025	\$50.36	\$8.65	\$23.05	\$0.00	\$82.06

Classification

Effective Date Base Wage Health Pension Supplemental Unemployment Total Rate

Apprentice - PAINTER - Local 35 Zone 2 - BRUSH NEW

Effective Date - 07/01/2022

Step	percent	Apprentice Base Wage	Health	Pension	Supplemental Unemployment	Total Rate
1	50	\$22.18	\$8.65	\$0.00	\$0.00	\$30.83
2	55	\$24.40	\$8.65	\$6.27	\$0.00	\$39.32
3	60	\$26.62	\$8.65	\$6.84	\$0.00	\$42.11
4	65	\$28.83	\$8.65	\$7.41	\$0.00	\$44.89
5	70	\$31.05	\$8.65	\$19.63	\$0.00	\$59.33
6	75	\$33.27	\$8.65	\$20.20	\$0.00	\$62.12
7	80	\$35.49	\$8.65	\$20.77	\$0.00	\$64.91
8	90	\$39.92	\$8.65	\$21.91	\$0.00	\$70.48

Effective Date - 01/01/2023

Step	percent	Apprentice Base Wage	Health	Pension	Supplemental Unemployment	Total Rate
1	50	\$22.78	\$8.65	\$0.00	\$0.00	\$31.43
2	55	\$25.06	\$8.65	\$6.27	\$0.00	\$39.98
3	60	\$27.34	\$8.65	\$6.84	\$0.00	\$42.83
4	65	\$29.61	\$8.65	\$7.41	\$0.00	\$45.67
5	70	\$31.89	\$8.65	\$19.63	\$0.00	\$60.17
6	75	\$34.17	\$8.65	\$20.20	\$0.00	\$63.02
7	80	\$36.45	\$8.65	\$20.77	\$0.00	\$65.87
8	90	\$41.00	\$8.65	\$21.91	\$0.00	\$71.56

Notes:
Steps are 750 hrs.

Apprentice to Journeyworker Ratio:1:1

PAINTER / TAPER (BRUSH, REPAINT)	07/01/2022	\$42.42	\$8.65	\$23.05	\$0.00	\$74.12
PAINTERS LOCAL 35 - ZONE 2	01/01/2023	\$43.62	\$8.65	\$23.05	\$0.00	\$75.32
	07/01/2023	\$44.82	\$8.65	\$23.05	\$0.00	\$76.52
	01/01/2024	\$46.02	\$8.65	\$23.05	\$0.00	\$77.72
	07/01/2024	\$47.22	\$8.65	\$23.05	\$0.00	\$78.92
	01/01/2025	\$48.42	\$8.65	\$23.05	\$0.00	\$80.12

Classification

Effective Date Base Wage Health Pension Supplemental Unemployment Total Rate

Apprentice - PAINTER Local 35 Zone 2 - BRUSH REPAINT

Effective Date - 07/01/2022

Step	percent	Apprentice Base Wage	Health	Pension	Supplemental Unemployment	Total Rate
1	50	\$21.21	\$8.65	\$0.00	\$0.00	\$29.86
2	55	\$23.33	\$8.65	\$6.27	\$0.00	\$38.25
3	60	\$25.45	\$8.65	\$6.84	\$0.00	\$40.94
4	65	\$27.57	\$8.65	\$7.41	\$0.00	\$43.63
5	70	\$29.69	\$8.65	\$19.63	\$0.00	\$57.97
6	75	\$31.82	\$8.65	\$20.20	\$0.00	\$60.67
7	80	\$33.94	\$8.65	\$20.77	\$0.00	\$63.36
8	90	\$38.18	\$8.65	\$21.91	\$0.00	\$68.74

Effective Date - 01/01/2023

Step	percent	Apprentice Base Wage	Health	Pension	Supplemental Unemployment	Total Rate
1	50	\$21.81	\$8.65	\$0.00	\$0.00	\$30.46
2	55	\$23.99	\$8.65	\$6.27	\$0.00	\$38.91
3	60	\$26.17	\$8.65	\$6.84	\$0.00	\$41.66
4	65	\$28.35	\$8.65	\$7.41	\$0.00	\$44.41
5	70	\$30.53	\$8.65	\$19.63	\$0.00	\$58.81
6	75	\$32.72	\$8.65	\$20.20	\$0.00	\$61.57
7	80	\$34.90	\$8.65	\$20.77	\$0.00	\$64.32
8	90	\$39.26	\$8.65	\$21.91	\$0.00	\$69.82

Notes:

Steps are 750 hrs.

Apprentice to Journeyworker Ratio:1:1

PAINTER TRAFFIC MARKINGS (HEAVY/HIGHWAY) LABORERS - ZONE 2 (HEAVY & HIGHWAY)	12/01/2021	\$35.41	\$9.10	\$16.64	\$0.00	\$61.15
---	------------	---------	--------	---------	--------	---------

For apprentice rates see "Apprentice- LABORER (Heavy and Highway)

PANEL & PICKUP TRUCKS DRIVER TEAMSTERS JOINT COUNCIL NO. 10 ZONE B	12/01/2021	\$35.78	\$13.41	\$16.01	\$0.00	\$65.20
---	------------	---------	---------	---------	--------	---------

PIER AND DOCK CONSTRUCTOR (UNDERPINNING AND DECK) PILE DRIVER LOCAL 56 (ZONE 1)	08/01/2020	\$49.07	\$9.40	\$23.12	\$0.00	\$81.59
--	------------	---------	--------	---------	--------	---------

For apprentice rates see "Apprentice- PILE DRIVER"

PILE DRIVER PILE DRIVER LOCAL 56 (ZONE 1)	08/01/2020	\$49.07	\$9.40	\$23.12	\$0.00	\$81.59
--	------------	---------	--------	---------	--------	---------

Classification

Effective Date Base Wage Health Pension Supplemental Unemployment Total Rate

Apprentice - PILE DRIVER - Local 56 Zone 1

Effective Date - 08/01/2020

Step	percent	Apprentice Base Wage	Health	Pension	Supplemental Unemployment	Total Rate
1	50	\$24.54	\$9.40	\$23.12	\$0.00	\$57.06
2	60	\$29.44	\$9.40	\$23.12	\$0.00	\$61.96
3	70	\$34.35	\$9.40	\$23.12	\$0.00	\$66.87
4	75	\$36.80	\$9.40	\$23.12	\$0.00	\$69.32
5	80	\$39.26	\$9.40	\$23.12	\$0.00	\$71.78
6	80	\$39.26	\$9.40	\$23.12	\$0.00	\$71.78
7	90	\$44.16	\$9.40	\$23.12	\$0.00	\$76.68
8	90	\$44.16	\$9.40	\$23.12	\$0.00	\$76.68

Notes:
 % Indentured After 10/1/17; 45/45/55/55/70/70/80/80
 Step 1&2 \$34.01/ 3&4 \$41.46/ 5&6 \$62.80/ 7&8 \$69.25

Apprentice to Journeyworker Ratio:1:5

PIPEFITTER & STEAMFITTER PIPEFITTERS LOCAL 537	03/01/2021	\$57.94	\$11.70	\$20.24	\$0.00	\$89.88
---	------------	---------	---------	---------	--------	---------

Apprentice - PIPEFITTER - Local 537

Effective Date - 03/01/2021

Step	percent	Apprentice Base Wage	Health	Pension	Supplemental Unemployment	Total Rate
1	40	\$23.18	\$11.70	\$8.25	\$0.00	\$43.13
2	45	\$26.07	\$11.70	\$20.24	\$0.00	\$58.01
3	60	\$34.76	\$11.70	\$20.24	\$0.00	\$66.70
4	70	\$40.56	\$11.70	\$20.24	\$0.00	\$72.50
5	80	\$46.35	\$11.70	\$20.24	\$0.00	\$78.29

Notes:
 ** 1:3; 3:15; 1:10 thereafter / Steps are 1 yr.
 Refrig/AC Mechanic **1:1;1:2;2:4;3:6;4:8;5:10;6:12;7:14;8:17;9:20;10:23(Max)

Apprentice to Journeyworker Ratio:**

PIPELAYER LABORERS - ZONE 2	06/01/2022	\$36.56	\$9.10	\$16.64	\$0.00	\$62.30
	12/01/2022	\$37.41	\$9.10	\$16.64	\$0.00	\$63.15
	06/01/2023	\$38.31	\$9.10	\$16.64	\$0.00	\$64.05
	12/01/2023	\$39.21	\$9.10	\$16.64	\$0.00	\$64.95

For apprentice rates see "Apprentice- LABORER"

PIPELAYER (HEAVY & HIGHWAY) LABORERS - ZONE 2 (HEAVY & HIGHWAY)	12/01/2021	\$35.66	\$9.10	\$16.64	\$0.00	\$61.40
--	------------	---------	--------	---------	--------	---------

For apprentice rates see "Apprentice- LABORER (Heavy and Highway)"

Classification	Effective Date	Base Wage	Health	Pension	Supplemental Unemployment	Total Rate
PLUMBERS & GASFITTERS <i>PLUMBERS & GASFITTERS LOCAL 12</i>	09/04/2022	\$63.49	\$14.07	\$18.36	\$0.00	\$95.92
	02/26/2023	\$65.19	\$14.07	\$18.36	\$0.00	\$97.62
	09/03/2023	\$66.94	\$14.07	\$18.36	\$0.00	\$99.37
	03/03/2024	\$68.74	\$14.07	\$18.36	\$0.00	\$101.17
	09/01/2024	\$70.54	\$14.07	\$18.36	\$0.00	\$102.97
	03/02/2025	\$72.34	\$14.07	\$18.36	\$0.00	\$104.77

Apprentice - PLUMBER/GASFITTER - Local 12

Effective Date - 09/04/2022

Step	percent	Apprentice Base Wage	Health	Pension	Supplemental Unemployment	Total Rate
1	35	\$22.22	\$14.07	\$6.63	\$0.00	\$42.92
2	40	\$25.40	\$14.07	\$7.52	\$0.00	\$46.99
3	55	\$34.92	\$14.07	\$10.24	\$0.00	\$59.23
4	65	\$41.27	\$14.07	\$12.04	\$0.00	\$67.38
5	75	\$47.62	\$14.07	\$13.85	\$0.00	\$75.54

Effective Date - 02/26/2023

Step	percent	Apprentice Base Wage	Health	Pension	Supplemental Unemployment	Total Rate
1	35	\$22.82	\$14.07	\$6.63	\$0.00	\$43.52
2	40	\$26.08	\$14.07	\$7.52	\$0.00	\$47.67
3	55	\$35.85	\$14.07	\$10.24	\$0.00	\$60.16
4	65	\$42.37	\$14.07	\$12.04	\$0.00	\$68.48
5	75	\$48.89	\$14.07	\$13.85	\$0.00	\$76.81

Notes:

** 1:2; 2:6; 3:10; 4:14; 5:19/Steps are 1 yr
Step4 with lic\$69.00, Step5 with lic\$76.87

Apprentice to Journeyworker Ratio:**

PNEUMATIC CONTROLS (TEMP.) <i>PIPEFITTERS LOCAL 537</i>	03/01/2021	\$57.94	\$11.70	\$20.24	\$0.00	\$89.88
--	------------	---------	---------	---------	--------	---------

For apprentice rates see "Apprentice- PIPEFITTER" or "PLUMBER/PIPEFITTER"

PNEUMATIC DRILL/TOOL OPERATOR <i>LABORERS - ZONE 2</i>	06/01/2022	\$36.56	\$9.10	\$16.64	\$0.00	\$62.30
	12/01/2022	\$37.41	\$9.10	\$16.64	\$0.00	\$63.15
	06/01/2023	\$38.31	\$9.10	\$16.64	\$0.00	\$64.05
	12/01/2023	\$39.21	\$9.10	\$16.64	\$0.00	\$64.95

For apprentice rates see "Apprentice- LABORER"

PNEUMATIC DRILL/TOOL OPERATOR (HEAVY & HIGHWAY) <i>LABORERS - ZONE 2 (HEAVY & HIGHWAY)</i>	12/01/2021	\$35.66	\$9.10	\$16.64	\$0.00	\$61.40
---	------------	---------	--------	---------	--------	---------

For apprentice rates see "Apprentice- LABORER (Heavy and Highway)"

POWDERMAN & BLASTER <i>LABORERS - ZONE 2</i>	06/01/2022	\$37.31	\$9.10	\$16.64	\$0.00	\$63.05
	12/01/2022	\$38.16	\$9.10	\$16.64	\$0.00	\$63.90
	06/01/2023	\$39.06	\$9.10	\$16.64	\$0.00	\$64.80
	12/01/2023	\$39.96	\$9.10	\$16.64	\$0.00	\$65.70

For apprentice rates see "Apprentice- LABORER"

POWDERMAN & BLASTER (HEAVY & HIGHWAY) <i>LABORERS - ZONE 2 (HEAVY & HIGHWAY)</i>	12/01/2021	\$36.41	\$9.10	\$16.64	\$0.00	\$62.15
---	------------	---------	--------	---------	--------	---------

For apprentice rates see "Apprentice- LABORER (Heavy and Highway)"

Classification	Effective Date	Base Wage	Health	Pension	Supplemental Unemployment	Total Rate
POWER SHOVEL/DERRICK/TRENCHING MACHINE <i>OPERATING ENGINEERS LOCAL 4</i>	06/01/2022	\$52.38	\$14.25	\$16.05	\$0.00	\$82.68
	12/01/2022	\$53.63	\$14.25	\$16.05	\$0.00	\$83.93
	06/01/2023	\$54.88	\$14.25	\$16.05	\$0.00	\$85.18
	12/01/2023	\$56.13	\$14.25	\$16.05	\$0.00	\$86.43
	06/01/2024	\$57.43	\$14.25	\$16.05	\$0.00	\$87.73
	12/01/2024	\$58.88	\$14.25	\$16.05	\$0.00	\$89.18
	06/01/2025	\$60.18	\$14.25	\$16.05	\$0.00	\$90.48
	12/01/2025	\$61.63	\$14.25	\$16.05	\$0.00	\$91.93
	06/01/2026	\$62.93	\$14.25	\$16.05	\$0.00	\$93.23
	12/01/2026	\$64.38	\$14.25	\$16.05	\$0.00	\$94.68
For apprentice rates see "Apprentice- OPERATING ENGINEERS"						
PUMP OPERATOR (CONCRETE) <i>OPERATING ENGINEERS LOCAL 4</i>	06/01/2022	\$52.38	\$14.25	\$16.05	\$0.00	\$82.68
	12/01/2022	\$53.63	\$14.25	\$16.05	\$0.00	\$83.93
	06/01/2023	\$54.88	\$14.25	\$16.05	\$0.00	\$85.18
	12/01/2023	\$56.13	\$14.25	\$16.05	\$0.00	\$86.43
	06/01/2024	\$57.43	\$14.25	\$16.05	\$0.00	\$87.73
	12/01/2024	\$58.88	\$14.25	\$16.05	\$0.00	\$89.18
	06/01/2025	\$60.18	\$14.25	\$16.05	\$0.00	\$90.48
	12/01/2025	\$61.63	\$14.25	\$16.05	\$0.00	\$91.93
	06/01/2026	\$62.93	\$14.25	\$16.05	\$0.00	\$93.23
	12/01/2026	\$64.38	\$14.25	\$16.05	\$0.00	\$94.68
For apprentice rates see "Apprentice- OPERATING ENGINEERS"						
PUMP OPERATOR (DEWATERING, OTHER) <i>OPERATING ENGINEERS LOCAL 4</i>	06/01/2022	\$34.26	\$14.25	\$16.05	\$0.00	\$64.56
	12/01/2022	\$35.08	\$14.25	\$16.05	\$0.00	\$65.38
	06/01/2023	\$35.90	\$14.25	\$16.05	\$0.00	\$66.20
	12/01/2023	\$36.72	\$14.25	\$16.05	\$0.00	\$67.02
	06/01/2024	\$37.57	\$14.25	\$16.05	\$0.00	\$67.87
	12/01/2024	\$38.52	\$14.25	\$16.05	\$0.00	\$68.82
	06/01/2025	\$39.37	\$14.25	\$16.05	\$0.00	\$69.67
	12/01/2025	\$40.32	\$14.25	\$16.05	\$0.00	\$70.62
	06/01/2026	\$41.18	\$14.25	\$16.05	\$0.00	\$71.48
	12/01/2026	\$42.13	\$14.25	\$16.05	\$0.00	\$72.43
For apprentice rates see "Apprentice- OPERATING ENGINEERS"						
READY-MIX CONCRETE DRIVER <i>TEAMSTERS 170 - J.G. MacLellan (Lowell)</i>	05/01/2022	\$25.85	\$10.37	\$6.35	\$0.00	\$42.57
	01/01/2023	\$25.85	\$10.77	\$6.35	\$0.00	\$42.97
RECLAIMERS <i>OPERATING ENGINEERS LOCAL 4</i>	06/01/2022	\$51.82	\$14.25	\$16.05	\$0.00	\$82.12
	12/01/2022	\$53.05	\$14.25	\$16.05	\$0.00	\$83.35
	06/01/2023	\$54.29	\$14.25	\$16.05	\$0.00	\$84.59
	12/01/2023	\$55.53	\$14.25	\$16.05	\$0.00	\$85.83
	06/01/2024	\$56.81	\$14.25	\$16.05	\$0.00	\$87.11
	12/01/2024	\$58.25	\$14.25	\$16.05	\$0.00	\$88.55
	06/01/2025	\$59.53	\$14.25	\$16.05	\$0.00	\$89.83
	12/01/2025	\$60.97	\$14.25	\$16.05	\$0.00	\$91.27
	06/01/2026	\$62.25	\$14.25	\$16.05	\$0.00	\$92.55
	12/01/2026	\$63.69	\$14.25	\$16.05	\$0.00	\$93.99
For apprentice rates see "Apprentice- OPERATING ENGINEERS"						

Classification	Effective Date	Base Wage	Health	Pension	Supplemental Unemployment	Total Rate
RIDE-ON MOTORIZED BUGGY OPERATOR <i>LABORERS - ZONE 2</i>	06/01/2022	\$36.56	\$9.10	\$16.64	\$0.00	\$62.30
	12/01/2022	\$37.41	\$9.10	\$16.64	\$0.00	\$63.15
	06/01/2023	\$38.31	\$9.10	\$16.64	\$0.00	\$64.05
	12/01/2023	\$39.21	\$9.10	\$16.64	\$0.00	\$64.95
For apprentice rates see "Apprentice- LABORER"						
ROLLER/SPREADER/MULCHING MACHINE <i>OPERATING ENGINEERS LOCAL 4</i>	06/01/2022	\$51.82	\$14.25	\$16.05	\$0.00	\$82.12
	12/01/2022	\$53.05	\$14.25	\$16.05	\$0.00	\$83.35
	06/01/2023	\$54.29	\$14.25	\$16.05	\$0.00	\$84.59
	12/01/2023	\$55.53	\$14.25	\$16.05	\$0.00	\$85.83
	06/01/2024	\$56.81	\$14.25	\$16.05	\$0.00	\$87.11
	12/01/2024	\$58.25	\$14.25	\$16.05	\$0.00	\$88.55
	06/01/2025	\$59.53	\$14.25	\$16.05	\$0.00	\$89.83
	12/01/2025	\$60.97	\$14.25	\$16.05	\$0.00	\$91.27
	06/01/2026	\$62.25	\$14.25	\$16.05	\$0.00	\$92.55
12/01/2026	\$63.69	\$14.25	\$16.05	\$0.00	\$93.99	
For apprentice rates see "Apprentice- OPERATING ENGINEERS"						
ROOFER (Inc.Roofing Waterproofng &Roofing Damproofg) <i>ROOFERS LOCAL 33</i>	02/01/2022	\$47.03	\$12.28	\$19.45	\$0.00	\$78.76

Apprentice - ROOFER - Local 33

Effective Date - 02/01/2022

Step	percent	Apprentice Base Wage	Health	Pension	Supplemental Unemployment	Total Rate
1	50	\$23.52	\$12.28	\$5.21	\$0.00	\$41.01
2	60	\$28.22	\$12.28	\$19.45	\$0.00	\$59.95
3	65	\$30.57	\$12.28	\$19.45	\$0.00	\$62.30
4	75	\$35.27	\$12.28	\$19.45	\$0.00	\$67.00
5	85	\$39.98	\$12.28	\$19.45	\$0.00	\$71.71

Notes: ** 1:5, 2:6-10, the 1:10; Reroofing: 1:4, then 1:1
Step 1 is 2000 hrs.; Steps 2-5 are 1000 hrs.
(Hot Pitch Mechanics' receive \$1.00 hr. above ROOFER)

Apprentice to Journeyworker Ratio:**

ROOFER SLATE / TILE / PRECAST CONCRETE <i>ROOFERS LOCAL 33</i>	02/01/2022	\$47.28	\$12.28	\$19.45	\$0.00	\$79.01
For apprentice rates see "Apprentice- ROOFER"						
SHEETMETAL WORKER <i>SHEETMETAL WORKERS LOCAL 17 - A</i>	02/01/2022	\$53.70	\$13.80	\$25.60	\$2.79	\$95.89

Classification

Effective Date Base Wage Health Pension Supplemental Unemployment Total Rate

Apprentice - SHEET METAL WORKER - Local 17-A

Effective Date - 02/01/2022

Step	percent	Apprentice Base Wage	Health	Pension	Supplemental Unemployment	Total Rate
1	42	\$22.55	\$13.80	\$6.01	\$0.00	\$42.36
2	42	\$22.55	\$13.80	\$6.01	\$0.00	\$42.36
3	47	\$25.24	\$13.80	\$11.26	\$1.51	\$51.81
4	47	\$25.24	\$13.80	\$11.26	\$1.51	\$51.81
5	52	\$27.92	\$13.80	\$12.23	\$1.62	\$55.57
6	52	\$27.92	\$13.80	\$12.48	\$1.63	\$55.83
7	60	\$32.22	\$13.80	\$13.87	\$1.80	\$61.69
8	65	\$34.91	\$13.80	\$14.84	\$1.91	\$65.46
9	75	\$40.28	\$13.80	\$16.77	\$2.13	\$72.98
10	85	\$45.65	\$13.80	\$18.20	\$2.33	\$79.98

Notes:
Steps are 6 mos.

Apprentice to Journeyworker Ratio:1:4

SPECIALIZED EARTH MOVING EQUIP < 35 TONS <i>TEAMSTERS JOINT COUNCIL NO. 10 ZONE B</i>	12/01/2021	\$36.24	\$13.41	\$16.01	\$0.00	\$65.66
SPECIALIZED EARTH MOVING EQUIP > 35 TONS <i>TEAMSTERS JOINT COUNCIL NO. 10 ZONE B</i>	12/01/2021	\$36.53	\$13.41	\$16.01	\$0.00	\$65.95
SPRINKLER FITTER <i>SPRINKLER FITTERS LOCAL 550 - (Section A) Zone 1</i>	10/01/2022	\$65.56	\$15.50	\$22.10	\$0.00	\$103.16
	03/01/2023	\$67.26	\$15.50	\$22.10	\$0.00	\$104.86
	10/01/2023	\$69.01	\$15.50	\$22.10	\$0.00	\$106.61
	03/01/2024	\$70.81	\$15.50	\$22.10	\$0.00	\$108.41
	10/01/2024	\$72.61	\$15.50	\$22.10	\$0.00	\$110.21
	03/01/2025	\$74.41	\$15.50	\$22.10	\$0.00	\$112.01

Apprentice - SPRINKLER FITTER - Local 550 (Section A) Zone 1

Effective Date - 10/01/2022

Step	percent	Apprentice Base Wage	Health	Pension	Supplemental Unemployment	Total Rate
1	35	\$22.95	\$15.50	\$9.60	\$0.00	\$48.05
2	40	\$26.22	\$15.50	\$9.60	\$0.00	\$51.32
3	45	\$29.50	\$15.50	\$9.60	\$0.00	\$54.60
4	50	\$32.78	\$15.50	\$9.60	\$0.00	\$57.88
5	55	\$36.06	\$15.50	\$9.60	\$0.00	\$61.16
6	60	\$39.34	\$15.50	\$11.10	\$0.00	\$65.94
7	65	\$42.61	\$15.50	\$11.10	\$0.00	\$69.21
8	70	\$45.89	\$15.50	\$11.10	\$0.00	\$72.49
9	75	\$49.17	\$15.50	\$11.10	\$0.00	\$75.77
10	80	\$52.45	\$15.50	\$11.10	\$0.00	\$79.05

Effective Date - 03/01/2023

Step	percent	Apprentice Base Wage	Health	Pension	Supplemental Unemployment	Total Rate
1	35	\$23.54	\$15.50	\$9.60	\$0.00	\$48.64
2	40	\$26.90	\$15.50	\$9.60	\$0.00	\$52.00
3	45	\$30.27	\$15.50	\$9.60	\$0.00	\$55.37
4	50	\$33.63	\$15.50	\$9.60	\$0.00	\$58.73
5	55	\$36.99	\$15.50	\$9.60	\$0.00	\$62.09
6	60	\$40.36	\$15.50	\$11.10	\$0.00	\$66.96
7	65	\$43.72	\$15.50	\$11.10	\$0.00	\$70.32
8	70	\$47.08	\$15.50	\$11.10	\$0.00	\$73.68
9	75	\$50.45	\$15.50	\$11.10	\$0.00	\$77.05
10	80	\$53.81	\$15.50	\$11.10	\$0.00	\$80.41

Notes: Apprentice entered prior 9/30/10:
40/45/50/55/60/65/70/75/80/85
Steps are 850 hours

Apprentice to Journeyworker Ratio:1:3

STEAM BOILER OPERATOR	06/01/2022	\$51.82	\$14.25	\$16.05	\$0.00	\$82.12
OPERATING ENGINEERS LOCAL 4	12/01/2022	\$53.05	\$14.25	\$16.05	\$0.00	\$83.35
	06/01/2023	\$54.29	\$14.25	\$16.05	\$0.00	\$84.59
	12/01/2023	\$55.53	\$14.25	\$16.05	\$0.00	\$85.83
	06/01/2024	\$56.81	\$14.25	\$16.05	\$0.00	\$87.11
	12/01/2024	\$58.25	\$14.25	\$16.05	\$0.00	\$88.55
	06/01/2025	\$59.53	\$14.25	\$16.05	\$0.00	\$89.83
	12/01/2025	\$60.97	\$14.25	\$16.05	\$0.00	\$91.27
	06/01/2026	\$62.25	\$14.25	\$16.05	\$0.00	\$92.55
	12/01/2026	\$63.69	\$14.25	\$16.05	\$0.00	\$93.99

For apprentice rates see "Apprentice- OPERATING ENGINEERS"

Classification	Effective Date	Base Wage	Health	Pension	Supplemental Unemployment	Total Rate
TAMPERS, SELF-PROPELLED OR TRACTOR DRAWN OPERATING ENGINEERS LOCAL 4	06/01/2022	\$51.82	\$14.25	\$16.05	\$0.00	\$82.12
	12/01/2022	\$53.05	\$14.25	\$16.05	\$0.00	\$83.35
	06/01/2023	\$54.29	\$14.25	\$16.05	\$0.00	\$84.59
	12/01/2023	\$55.53	\$14.25	\$16.05	\$0.00	\$85.83
	06/01/2024	\$56.81	\$14.25	\$16.05	\$0.00	\$87.11
	12/01/2024	\$58.25	\$14.25	\$16.05	\$0.00	\$88.55
	06/01/2025	\$59.53	\$14.25	\$16.05	\$0.00	\$89.83
	12/01/2025	\$60.97	\$14.25	\$16.05	\$0.00	\$91.27
	06/01/2026	\$62.25	\$14.25	\$16.05	\$0.00	\$92.55
	12/01/2026	\$63.69	\$14.25	\$16.05	\$0.00	\$93.99

For apprentice rates see "Apprentice- OPERATING ENGINEERS"

TERRAZZO FINISHERS BRICKLAYERS LOCAL 3 - MARBLE & TILE	08/01/2022	\$58.09	\$11.49	\$22.34	\$0.00	\$91.92
	02/01/2023	\$59.29	\$11.49	\$22.34	\$0.00	\$93.12
	08/01/2023	\$61.34	\$11.49	\$22.34	\$0.00	\$95.17
	02/01/2024	\$62.59	\$11.49	\$22.34	\$0.00	\$96.42
	08/01/2024	\$64.69	\$11.49	\$22.34	\$0.00	\$98.52
	02/01/2025	\$65.99	\$11.49	\$22.34	\$0.00	\$99.82
	08/01/2025	\$68.14	\$11.49	\$22.34	\$0.00	\$101.97
	02/01/2026	\$69.49	\$11.49	\$22.34	\$0.00	\$103.32
	08/01/2026	\$71.69	\$11.49	\$22.34	\$0.00	\$105.52
	02/01/2027	\$73.09	\$11.49	\$22.34	\$0.00	\$106.92

Apprentice - TERRAZZO FINISHER - Local 3 Marble & Tile

Effective Date - 08/01/2022

Step	percent	Apprentice Base Wage	Health	Pension	Supplemental Unemployment	Total Rate
1	50	\$29.05	\$11.49	\$22.34	\$0.00	\$62.88
2	60	\$34.85	\$11.49	\$22.34	\$0.00	\$68.68
3	70	\$40.66	\$11.49	\$22.34	\$0.00	\$74.49
4	80	\$46.47	\$11.49	\$22.34	\$0.00	\$80.30
5	90	\$52.28	\$11.49	\$22.34	\$0.00	\$86.11

Effective Date - 02/01/2023

Step	percent	Apprentice Base Wage	Health	Pension	Supplemental Unemployment	Total Rate
1	50	\$29.65	\$11.49	\$22.34	\$0.00	\$63.48
2	60	\$35.57	\$11.49	\$22.34	\$0.00	\$69.40
3	70	\$41.50	\$11.49	\$22.34	\$0.00	\$75.33
4	80	\$47.43	\$11.49	\$22.34	\$0.00	\$81.26
5	90	\$53.36	\$11.49	\$22.34	\$0.00	\$87.19

Notes:

Apprentice to Journeyworker Ratio:1:3

TEST BORING DRILLER LABORERS - FOUNDATION AND MARINE	12/01/2021	\$42.58	\$9.10	\$17.72	\$0.00	\$69.40
---	------------	---------	--------	---------	--------	---------

For apprentice rates see "Apprentice- LABORER"

Classification	Effective Date	Base Wage	Health	Pension	Supplemental Unemployment	Total Rate
TEST BORING DRILLER HELPER <i>LABORERS - FOUNDATION AND MARINE</i>	12/01/2021	\$41.30	\$9.10	\$17.72	\$0.00	\$68.12
For apprentice rates see "Apprentice- LABORER"						
TEST BORING LABORER <i>LABORERS - FOUNDATION AND MARINE</i>	12/01/2021	\$41.18	\$9.10	\$17.72	\$0.00	\$68.00
For apprentice rates see "Apprentice- LABORER"						
TRACTORS/PORTABLE STEAM GENERATORS <i>OPERATING ENGINEERS LOCAL 4</i>	06/01/2022	\$51.82	\$14.25	\$16.05	\$0.00	\$82.12
	12/01/2022	\$53.05	\$14.25	\$16.05	\$0.00	\$83.35
	06/01/2023	\$54.29	\$14.25	\$16.05	\$0.00	\$84.59
	12/01/2023	\$55.53	\$14.25	\$16.05	\$0.00	\$85.83
	06/01/2024	\$56.81	\$14.25	\$16.05	\$0.00	\$87.11
	12/01/2024	\$58.25	\$14.25	\$16.05	\$0.00	\$88.55
	06/01/2025	\$59.53	\$14.25	\$16.05	\$0.00	\$89.83
	12/01/2025	\$60.97	\$14.25	\$16.05	\$0.00	\$91.27
	06/01/2026	\$62.25	\$14.25	\$16.05	\$0.00	\$92.55
	12/01/2026	\$63.69	\$14.25	\$16.05	\$0.00	\$93.99
For apprentice rates see "Apprentice- OPERATING ENGINEERS"						
TRAILERS FOR EARTH MOVING EQUIPMENT <i>TEAMSTERS JOINT COUNCIL NO. 10 ZONE B</i>	12/01/2021	\$36.82	\$13.41	\$16.01	\$0.00	\$66.24
TUNNEL WORK - COMPRESSED AIR <i>LABORERS (COMPRESSED AIR)</i>	12/01/2021	\$53.41	\$9.10	\$18.17	\$0.00	\$80.68
For apprentice rates see "Apprentice- LABORER"						
TUNNEL WORK - COMPRESSED AIR (HAZ. WASTE) <i>LABORERS (COMPRESSED AIR)</i>	12/01/2021	\$55.41	\$9.10	\$18.17	\$0.00	\$82.68
For apprentice rates see "Apprentice- LABORER"						
TUNNEL WORK - FREE AIR <i>LABORERS (FREE AIR TUNNEL)</i>	12/01/2021	\$45.48	\$9.10	\$18.17	\$0.00	\$72.75
For apprentice rates see "Apprentice- LABORER"						
TUNNEL WORK - FREE AIR (HAZ. WASTE) <i>LABORERS (FREE AIR TUNNEL)</i>	12/01/2021	\$47.48	\$9.10	\$18.17	\$0.00	\$74.75
For apprentice rates see "Apprentice- LABORER"						
VAC-HAUL <i>TEAMSTERS JOINT COUNCIL NO. 10 ZONE B</i>	12/01/2021	\$36.24	\$13.41	\$16.01	\$0.00	\$65.66
VOICE-DATA-VIDEO TECHNICIAN <i>ELECTRICIANS LOCAL 96</i>	09/04/2022	\$34.19	\$12.20	\$15.91	\$0.00	\$62.30

Apprentice - VOICE-DATA-VIDEO TECHNICIAN - Local 96

Effective Date - 09/04/2022

Step	percent	Apprentice Base Wage	Health	Pension	Supplemental Unemployment	Total Rate
1	50	\$17.10	\$12.20	\$4.27	\$0.00	\$33.57
2	55	\$18.80	\$12.20	\$4.32	\$0.00	\$35.32
3	60	\$20.51	\$12.20	\$15.50	\$0.00	\$48.21
4	65	\$22.22	\$12.20	\$15.55	\$0.00	\$49.97
5	70	\$23.93	\$12.20	\$15.60	\$0.00	\$51.73
6	75	\$25.64	\$12.20	\$15.65	\$0.00	\$53.49
7	80	\$27.35	\$12.20	\$15.70	\$0.00	\$55.25
8	85	\$29.06	\$12.20	\$15.75	\$0.00	\$57.01

Notes:

Apprentice to Journeyworker Ratio:1:1

WAGON DRILL OPERATOR LABORERS - ZONE 2	06/01/2022	\$36.56	\$9.10	\$16.64	\$0.00	\$62.30
	12/01/2022	\$37.41	\$9.10	\$16.64	\$0.00	\$63.15
	06/01/2023	\$38.31	\$9.10	\$16.64	\$0.00	\$64.05
	12/01/2023	\$39.21	\$9.10	\$16.64	\$0.00	\$64.95

For apprentice rates see "Apprentice- LABORER"

WAGON DRILL OPERATOR (HEAVY & HIGHWAY) LABORERS - ZONE 2 (HEAVY & HIGHWAY)	12/01/2021	\$35.66	\$9.10	\$16.64	\$0.00	\$61.40
---	------------	---------	--------	---------	--------	---------

For apprentice rates see "Apprentice- LABORER (Heavy and Highway)"

WASTE WATER PUMP OPERATOR OPERATING ENGINEERS LOCAL 4	06/01/2022	\$52.38	\$14.25	\$16.05	\$0.00	\$82.68
	12/01/2022	\$53.63	\$14.25	\$16.05	\$0.00	\$83.93
	06/01/2023	\$54.88	\$14.25	\$16.05	\$0.00	\$85.18
	12/01/2023	\$56.13	\$14.25	\$16.05	\$0.00	\$86.43
	06/01/2024	\$57.43	\$14.25	\$16.05	\$0.00	\$87.73
	12/01/2024	\$58.88	\$14.25	\$16.05	\$0.00	\$89.18
	06/01/2025	\$60.18	\$14.25	\$16.05	\$0.00	\$90.48
	12/01/2025	\$61.63	\$14.25	\$16.05	\$0.00	\$91.93
	06/01/2026	\$62.93	\$14.25	\$16.05	\$0.00	\$93.23
	12/01/2026	\$64.38	\$14.25	\$16.05	\$0.00	\$94.68

For apprentice rates see "Apprentice- OPERATING ENGINEERS"

WATER METER INSTALLER PLUMBERS & GASFITTERS LOCAL 12	09/04/2022	\$63.49	\$14.07	\$18.36	\$0.00	\$95.92
	02/26/2023	\$65.19	\$14.07	\$18.36	\$0.00	\$97.62
	09/03/2023	\$66.94	\$14.07	\$18.36	\$0.00	\$99.37
	03/03/2024	\$68.74	\$14.07	\$18.36	\$0.00	\$101.17
	09/01/2024	\$70.54	\$14.07	\$18.36	\$0.00	\$102.97
	03/02/2025	\$72.34	\$14.07	\$18.36	\$0.00	\$104.77

For apprentice rates see "Apprentice- PLUMBER/PIPEFITTER" or "PLUMBER/GASFITTER"

Additional Apprentices Information:

Minimum wage rates for apprentices employed on public works projects are listed above as a percentage of the pre-determined hourly wage rate established by the Commissioner under the provisions of the M.G.L. c. 149, ss. 26-27D. Apprentices ratios are established by the Division of Apprenticeship Training pursuant to M.G.L. c. 23, ss. 11E-11L.

All apprentices must be registered with the Division of Apprenticeship Training in accordance with M.G.L. c. 23, ss. 11E-11L.

All steps are six months (1000 hours.)

Ratios are expressed in allowable number of apprentices to journeymen or fraction thereof, unless otherwise specified.

** Multiple ratios are listed in the comment field.

*** APP to JM; 1:1, 2:2, 2:3, 3:4, 4:4, 4:5, 4:6, 5:7, 6:7, 6:8, 6:9, 7:10, 8:10, 8:11, 8:12, 9:13, 10:13, 10:14, etc.

**** APP to JM; 1:1, 1:2, 2:3, 2:4, 3:5, 4:6, 4:7, 5:8, 6:9, 6:10, 7:11, 8:12, 8:13, 9:14, 10:15, 10:16, etc.

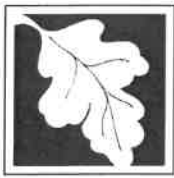

Massachusetts Department of Environmental Protection
Bureau of Resource Protection - Wetlands
WPA Form 5 – Order of Conditions
 Massachusetts Wetlands Protection Act M.G.L. c. 131, §40

Provided by MassDEP:
 299-719

MassDEP File # _____

eDEP Transaction # _____

City/Town _____

A. General Information (cont.)

6. Property recorded at the Registry of Deeds for (attach additional information if more than one parcel):
 Southern Middlesex (Captain Sargent CA/Red Acre Woodlands/Kunelius) _____
 14475/35452/71090 _____
 c. Book _____ b. Certificate Number (if registered land) _____
 583/112/379 _____
 d. Page _____
7. Dates: 8/19/2022 _____ 9/20/2022 _____ 9/27/2022 _____
 a. Date Notice of Intent Filed b. Date Public Hearing Closed c. Date of Issuance
8. Final Approved Plans and Other Documents (attach additional plan or document references as needed):
 Garden Entrance Concept Plan _____
 a. Plan Title _____
 J.Goring _____ N/A _____
 b. Prepared By c. Signed and Stamped by
 8/10/2022 _____ Not to Scale _____
 d. Final Revision Date e. Scale
 Captain Sargent Conservation Area and Red Acre Woodlands Trail 8/10/2022 _____
 Map and Design Sketch g. Date

B. Findings

1. Findings pursuant to the Massachusetts Wetlands Protection Act:
 Following the review of the above-referenced Notice of Intent and based on the information provided in this application and presented at the public hearing, this Commission finds that the areas in which work is proposed is significant to the following interests of the Wetlands Protection Act (the Act). Check all that apply:
- a. Public Water Supply b. Land Containing Shellfish c. Prevention of Pollution
 d. Private Water Supply e. Fisheries f. Protection of Wildlife Habitat
 g. Groundwater Supply h. Storm Damage Prevention i. Flood Control
2. This Commission hereby finds the project, as proposed, is: (check one of the following boxes)

Approved subject to:

- a. the following conditions which are necessary in accordance with the performance standards set forth in the wetlands regulations. This Commission orders that all work shall be performed in accordance with the Notice of Intent referenced above, the following General Conditions, and any other special conditions attached to this Order. To the extent that the following conditions modify or differ from the plans, specifications, or other proposals submitted with the Notice of Intent, these conditions shall control.

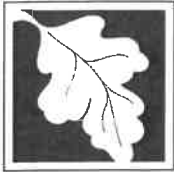

Massachusetts Department of Environmental Protection
Bureau of Resource Protection - Wetlands
WPA Form 5 – Order of Conditions
 Massachusetts Wetlands Protection Act M.G.L. c. 131, §40

Provided by MassDEP:
 299-719
 MassDEP File # _____
 eDEP Transaction # _____
 City/Town _____

B. Findings (cont.)

Coastal Resource Area Impacts: Check all that apply below. (For Approvals Only)

	Proposed Alteration	Permitted Alteration	Proposed Replacement	Permitted Replacement
10. <input type="checkbox"/> Designated Port Areas	Indicate size under Land Under the Ocean, below			
11. <input type="checkbox"/> Land Under the Ocean	a. square feet	b. square feet		
	c. c/y dredged	d. c/y dredged		
12. <input type="checkbox"/> Barrier Beaches	Indicate size under Coastal Beaches and/or Coastal Dunes below			
13. <input type="checkbox"/> Coastal Beaches	a. square feet	b. square feet	c. nourishment cu yd	d. nourishment cu yd
14. <input type="checkbox"/> Coastal Dunes	a. square feet	b. square feet	c. nourishment cu yd	d. nourishment cu yd
15. <input type="checkbox"/> Coastal Banks	a. linear feet	b. linear feet		
16. <input type="checkbox"/> Rocky Intertidal Shores	a. square feet	b. square feet		
17. <input type="checkbox"/> Salt Marshes	a. square feet	b. square feet	c. square feet	d. square feet
18. <input type="checkbox"/> Land Under Salt Ponds	a. square feet	b. square feet		
	c. c/y dredged	d. c/y dredged		
19. <input type="checkbox"/> Land Containing Shellfish	a. square feet	b. square feet	c. square feet	d. square feet
20. <input type="checkbox"/> Fish Runs	Indicate size under Coastal Banks, Inland Bank, Land Under the Ocean, and/or inland Land Under Waterbodies and Waterways, above			
	a. c/y dredged	b. c/y dredged		
21. <input type="checkbox"/> Land Subject to Coastal Storm Flowage	a. square feet	b. square feet		
22. <input type="checkbox"/> Riverfront Area	a. total sq. feet	b. total sq. feet		
Sq ft within 100 ft	c. square feet	d. square feet	e. square feet	f. square feet
Sq ft between 100-200 ft	g. square feet	h. square feet	i. square feet	j. square feet



Massachusetts Department of Environmental Protection
Bureau of Resource Protection - Wetlands
WPA Form 5 – Order of Conditions
 Massachusetts Wetlands Protection Act M.G.L. c. 131, §40

Provided by MassDEP:
 299-719
 MassDEP File # _____

eDEP Transaction # _____

City/Town _____

B. Findings (cont.)

* #23. If the project is for the purpose of restoring or enhancing a wetland resource area in addition to the square footage that has been entered in Section B.5.c (BVW) or B.17.c (Salt Marsh) above, please enter the additional amount here.

23. Restoration/Enhancement *:

a. square feet of BVW _____

b. square feet of salt marsh _____

24. Stream Crossing(s):

a. number of new stream crossings _____

b. number of replacement stream crossings _____

C. General Conditions Under Massachusetts Wetlands Protection Act

The following conditions are only applicable to Approved projects.

1. Failure to comply with all conditions stated herein, and with all related statutes and other regulatory measures, shall be deemed cause to revoke or modify this Order.
2. The Order does not grant any property rights or any exclusive privileges; it does not authorize any injury to private property or invasion of private rights.
3. This Order does not relieve the permittee or any other person of the necessity of complying with all other applicable federal, state, or local statutes, ordinances, bylaws, or regulations.
4. The work authorized hereunder shall be completed within three years from the date of this Order unless either of the following apply:
 - a. The work is a maintenance dredging project as provided for in the Act; or
 - b. The time for completion has been extended to a specified date more than three years, but less than five years, from the date of issuance. If this Order is intended to be valid for more than three years, the extension date and the special circumstances warranting the extended time period are set forth as a special condition in this Order.
 - c. If the work is for a Test Project, this Order of Conditions shall be valid for no more than one year.
5. This Order may be extended by the issuing authority for one or more periods of up to three years each upon application to the issuing authority at least 30 days prior to the expiration date of the Order. An Order of Conditions for a Test Project may be extended for one additional year only upon written application by the applicant, subject to the provisions of 310 CMR 10.05(11)(f).
6. If this Order constitutes an Amended Order of Conditions, this Amended Order of Conditions does not extend the issuance date of the original Final Order of Conditions and the Order will expire on 9/27/2025 unless extended in writing by the Department.
7. Any fill used in connection with this project shall be clean fill. Any fill shall contain no trash, refuse, rubbish, or debris, including but not limited to lumber, bricks, plaster, wire, lath, paper, cardboard, pipe, tires, ashes, refrigerators, motor vehicles, or parts of any of the foregoing.



Massachusetts Department of Environmental Protection
Bureau of Resource Protection - Wetlands
WPA Form 5 – Order of Conditions
 Massachusetts Wetlands Protection Act M.G.L. c. 131, §40

Provided by MassDEP:

299-719

MassDEP File #

eDEP Transaction #

City/Town

C. General Conditions Under Massachusetts Wetlands Protection Act

8. This Order is not final until all administrative appeal periods from this Order have elapsed, or if such an appeal has been taken, until all proceedings before the Department have been completed.
9. No work shall be undertaken until the Order has become final and then has been recorded in the Registry of Deeds or the Land Court for the district in which the land is located, within the chain of title of the affected property. In the case of recorded land, the Final Order shall also be noted in the Registry's Grantor Index under the name of the owner of the land upon which the proposed work is to be done. In the case of the registered land, the Final Order shall also be noted on the Land Court Certificate of Title of the owner of the land upon which the proposed work is done. The recording information shall be submitted to the Conservation Commission on the form at the end of this Order, which form must be stamped by the Registry of Deeds, prior to the commencement of work.
10. A sign shall be displayed at the site not less than two square feet or more than three square feet in size bearing the words,

"Massachusetts Department of Environmental Protection" [or, "MassDEP"]
 "File Number 299-719 "
11. Where the Department of Environmental Protection is requested to issue a Superseding Order, the Conservation Commission shall be a party to all agency proceedings and hearings before MassDEP.
12. Upon completion of the work described herein, the applicant shall submit a Request for Certificate of Compliance (WPA Form 8A) to the Conservation Commission.
13. The work shall conform to the plans and special conditions referenced in this order.
14. Any change to the plans identified in Condition #13 above shall require the applicant to inquire of the Conservation Commission in writing whether the change is significant enough to require the filing of a new Notice of Intent.
15. The Agent or members of the Conservation Commission and the Department of Environmental Protection shall have the right to enter and inspect the area subject to this Order at reasonable hours to evaluate compliance with the conditions stated in this Order, and may require the submittal of any data deemed necessary by the Conservation Commission or Department for that evaluation.
16. This Order of Conditions shall apply to any successor in interest or successor in control of the property subject to this Order and to any contractor or other person performing work conditioned by this Order.



Massachusetts Department of Environmental Protection
 Bureau of Resource Protection - Wetlands
WPA Form 5 – Order of Conditions
 Massachusetts Wetlands Protection Act M.G.L. c. 131, §40

Provided by MassDEP:
 299-719
 MassDEP File # _____

eDEP Transaction # _____

City/Town _____

C. General Conditions Under Massachusetts Wetlands Protection Act (cont.)

17. Prior to the start of work, and if the project involves work adjacent to a Bordering Vegetated Wetland, the boundary of the wetland in the vicinity of the proposed work area shall be marked by wooden stakes or flagging. Once in place, the wetland boundary markers shall be maintained until a Certificate of Compliance has been issued by the Conservation Commission.
18. All sedimentation barriers shall be maintained in good repair until all disturbed areas have been fully stabilized with vegetation or other means. At no time shall sediments be deposited in a wetland or water body. During construction, the applicant or his/her designee shall inspect the erosion controls on a daily basis and shall remove accumulated sediments as needed. The applicant shall immediately control any erosion problems that occur at the site and shall also immediately notify the Conservation Commission, which reserves the right to require additional erosion and/or damage prevention controls it may deem necessary. Sedimentation barriers shall serve as the limit of work unless another limit of work line has been approved by this Order.
19. The work associated with this Order (the "Project")
- (1) is subject to the Massachusetts Stormwater Standards
- (2) is NOT subject to the Massachusetts Stormwater Standards

If the work is subject to the Stormwater Standards, then the project is subject to the following conditions:

- a) All work, including site preparation, land disturbance, construction and redevelopment, shall be implemented in accordance with the construction period pollution prevention and erosion and sedimentation control plan and, if applicable, the Stormwater Pollution Prevention Plan required by the National Pollution Discharge Elimination System Construction General Permit as required by Stormwater Condition 8. Construction period erosion, sedimentation and pollution control measures and best management practices (BMPs) shall remain in place until the site is fully stabilized.
- b) No stormwater runoff may be discharged to the post-construction stormwater BMPs unless and until a Registered Professional Engineer provides a Certification that:
- i.* all construction period BMPs have been removed or will be removed by a date certain specified in the Certification. For any construction period BMPs intended to be converted to post construction operation for stormwater attenuation, recharge, and/or treatment, the conversion is allowed by the MassDEP Stormwater Handbook BMP specifications and that the BMP has been properly cleaned or prepared for post construction operation, including removal of all construction period sediment trapped in inlet and outlet control structures;
 - ii.* as-built final construction BMP plans are included, signed and stamped by a Registered Professional Engineer, certifying the site is fully stabilized;
 - iii.* any illicit discharges to the stormwater management system have been removed, as per the requirements of Stormwater Standard 10;



Massachusetts Department of Environmental Protection
Bureau of Resource Protection - Wetlands
WPA Form 5 – Order of Conditions
 Massachusetts Wetlands Protection Act M.G.L. c. 131, §40

Provided by MassDEP:
 299-719
 MassDEP File #

eDEP Transaction #

City/Town

C. General Conditions Under Massachusetts Wetlands Protection Act (cont.)

iv. all post-construction stormwater BMPs are installed in accordance with the plans (including all planting plans) approved by the issuing authority, and have been inspected to ensure that they are not damaged and that they are in proper working condition;

v. any vegetation associated with post-construction BMPs is suitably established to withstand erosion.

c) The landowner is responsible for BMP maintenance until the issuing authority is notified that another party has legally assumed responsibility for BMP maintenance. Prior to requesting a Certificate of Compliance, or Partial Certificate of Compliance, the responsible party (defined in General Condition 18(e)) shall execute and submit to the issuing authority an Operation and Maintenance Compliance Statement ("O&M Statement") for the Stormwater BMPs identifying the party responsible for implementing the stormwater BMP Operation and Maintenance Plan ("O&M Plan") and certifying the following:

i.) the O&M Plan is complete and will be implemented upon receipt of the Certificate of Compliance, and

ii.) the future responsible parties shall be notified in writing of their ongoing legal responsibility to operate and maintain the stormwater management BMPs and implement the Stormwater Pollution Prevention Plan.

d) Post-construction pollution prevention and source control shall be implemented in accordance with the long-term pollution prevention plan section of the approved Stormwater Report and, if applicable, the Stormwater Pollution Prevention Plan required by the National Pollution Discharge Elimination System Multi-Sector General Permit.

e) Unless and until another party accepts responsibility, the landowner, or owner of any drainage easement, assumes responsibility for maintaining each BMP. To overcome this presumption, the landowner of the property must submit to the issuing authority a legally binding agreement of record, acceptable to the issuing authority, evidencing that another entity has accepted responsibility for maintaining the BMP, and that the proposed responsible party shall be treated as a permittee for purposes of implementing the requirements of Conditions 18(f) through 18(k) with respect to that BMP. Any failure of the proposed responsible party to implement the requirements of Conditions 18(f) through 18(k) with respect to that BMP shall be a violation of the Order of Conditions or Certificate of Compliance. In the case of stormwater BMPs that are serving more than one lot, the legally binding agreement shall also identify the lots that will be serviced by the stormwater BMPs. A plan and easement deed that grants the responsible party access to perform the required operation and maintenance must be submitted along with the legally binding agreement.

f) The responsible party shall operate and maintain all stormwater BMPs in accordance with the design plans, the O&M Plan, and the requirements of the Massachusetts Stormwater Handbook.

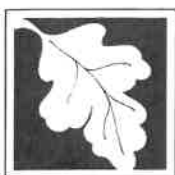

Massachusetts Department of Environmental Protection
Bureau of Resource Protection - Wetlands
WPA Form 5 – Order of Conditions
 Massachusetts Wetlands Protection Act M.G.L. c. 131, §40

Provided by MassDEP:
 299-719
 MassDEP File #

eDEP Transaction #

City/Town

C. General Conditions Under Massachusetts Wetlands Protection Act (cont.)

- g) The responsible party shall:
1. Maintain an operation and maintenance log for the last three (3) consecutive calendar years of inspections, repairs, maintenance and/or replacement of the stormwater management system or any part thereof, and disposal (for disposal the log shall indicate the type of material and the disposal location);
 2. Make the maintenance log available to MassDEP and the Conservation Commission ("Commission") upon request; and
 3. Allow members and agents of the MassDEP and the Commission to enter and inspect the site to evaluate and ensure that the responsible party is in compliance with the requirements for each BMP established in the O&M Plan approved by the issuing authority.
- h) All sediment or other contaminants removed from stormwater BMPs shall be disposed of in accordance with all applicable federal, state, and local laws and regulations.
- i) Illicit discharges to the stormwater management system as defined in 310 CMR 10.04 are prohibited.
- j) The stormwater management system approved in the Order of Conditions shall not be changed without the prior written approval of the issuing authority.
- k) Areas designated as qualifying pervious areas for the purpose of the Low Impact Site Design Credit (as defined in the MassDEP Stormwater Handbook, Volume 3, Chapter 1, Low Impact Development Site Design Credits) shall not be altered without the prior written approval of the issuing authority.
- l) Access for maintenance, repair, and/or replacement of BMPs shall not be withheld. Any fencing constructed around stormwater BMPs shall include access gates and shall be at least six inches above grade to allow for wildlife passage.

Special Conditions (if you need more space for additional conditions, please attach a text document):

See attached

20. For Test Projects subject to 310 CMR 10.05(11), the applicant shall also implement the monitoring plan and the restoration plan submitted with the Notice of Intent. If the conservation commission or Department determines that the Test Project threatens the public health, safety or the environment, the applicant shall implement the removal plan submitted with the Notice of Intent or modify the project as directed by the conservation commission or the Department.

ORDER OF CONDITIONS #299-0719
Massachusetts Wetlands Protection Act and Town of Stow Wetland Bylaw
Off Tuttle Lane & Red Acre Road, Stow, MA
Assessors Maps R30, Parcel 20 and R31, Parcel 57A

Findings:

The applicant has filed a Notice of Intent for work proposed within an area subject to protection under the Wetlands Protection Act, MGL CH 131, Section 40 and the Town of Stow Wetlands Protection Bylaw and Regulations. Portions of the sites are also subject to a permanent Conservation Restrictions held by the Stow Conservation Commission and Stow Conservation Trust.

The work proposed by Stow Conservation Department Staff and Stow Conservation Trust includes:

- Construction of a five-car pervious parking area and associated grading. Two farm gates on either side of the parking lot will be installed on the Community Garden road to limit vehicle traffic to gardener vehicles only.
- Trail construction and installation of a four-foot wide 360' long boardwalk on metal pipes with augers across a bordering vegetated wetland. This boardwalk will have piers/pipes installed at eight to ten-foot intervals with wood decking. The boardwalk will be no greater than 4' in width.

The proposed work has the potential to alter Bordering Vegetated Wetland. It also has the potential to alter the Town of Stow local bylaw 35' no disturb buffer. The pedestrian boardwalk work may be considered a limited project under 310 CMR 10.53(6). The location of the boardwalk is located within an existing trail and plywood "bog bridge" that was constructed without a permit and is adversely affecting the wetland. The existing boards will be removed and disposed of offsite. Portions of the work are also within Bordering Land Subject to Flooding, but, as proposed, will result in *di minimis* fill in the floodplain. There is no fill of wetland proposed.

The proposed crossing is within the 35' no disturb buffer area required by the Town of Stow Wetlands Regulations. The applicant has requested a waiver for this work. However, the Commission finds that it is appropriate to grant a waiver as this is a water dependent project which will provide safe pedestrian and wildlife passage over the wetland, completing a significant trail connection between Captain Sargent Conservation Area and Red Acre Woodlands, and fostering an appreciation for the wetland. The proposed boardwalk will also improve the existing condition which is damaging to the wetland by encouraging pedestrian and bike use without a proper boardwalk crossing.

Special Conditions:

20. A Stow Conservation Commissioner, agent of the Commission or the Department of Environmental Protection reserves the **right to enter and inspect the property at all reasonable times**, until a Certificate of Compliance is issued, to evaluate compliance with these conditions and to require submittal of any data deemed necessary by the Commission for that evaluation. Further, work shall be halted on the site if the

Commissioner, agent or DEP determines that any of the work is not in compliance with this Order. Work shall not resume until the Commission is satisfied that the work will comply, and has so notified the applicant in writing.

21. The form provided at the end of this Order shall be completed and stamped at the Middlesex Registry of Deeds, after the expiration of the 10-day appeal period and if no request for appeal has been filed with the Department of Environmental Protection. This form shall be returned to the Commission in accordance with General Condition #8, and prior to the commencement of work.
22. All work shall be performed in accordance with the final plans as described in the Notice of Intent or as specified in this Order of Conditions. Any deviation from the approved plans shall require prior approval from the Stow Conservation Commission. This may require resubmission or modification of the Notice of Intent.
23. **No fill, culverts or other materials shall be placed in floodplain or bordering vegetated wetland.**
24. All boardwalk work shall be performed during dry, low water, or frozen ground conditions.
25. **The Stow Conservation Commission shall be notified a minimum of 72 hours prior to the start of construction.** The applicant shall advise the Commission of the name(s) and telephone numbers(s) of the person(s) responsible on site for compliance with this Order. A copy of this Order including final plans shall be on the site upon commencement and during any site work for contractors and/or crew leaders to view and adhere to.
26. No dredging or filling of land beyond the limits or above the grades on the submitted plans is authorized.
27. All boardwalk work shall be done by hand. All pipes with augers shall be hand driven. The applicant shall make best efforts to construct bridges and boardwalks in sequence beginning at the entrance to the Premises so as to avoid physical impacts to wetlands from trail users seeking to cross wet areas. The trail shall be closed during construction and signage shall be used to ensure that the public is not using unfinished sections of the trail.
28. The areas of construction shall remain in a stable condition at the close of each construction day.
29. **Erosion control devices shall be as shown on the plan and straw wattles shall be at least 8 in in diameter.** Erosion controls shall be installed prior to the beginning of any phases of construction and shall be maintained during construction. These erosion controls shall serve as a limit of work and no activity, including stockpiling or storage of material, is permitted beyond the erosion controls. The erosion control specifications provided in the Notice of Intent and the erosion control provision in the Order will be the minimum standards for this project; the Commission may require additional measures.

These will be maintained until the disturbed area is re-vegetated and stabilized to the satisfaction of the Stow Conservation Commission at which time they must be removed. The Stow Conservation Commission shall be contacted and approval obtained prior to removal of erosion controls.

30. As no significant earth disturbing activities or soil stockpiles are proposed as part of the boardwalk construction, it is not anticipated that erosion controls will be necessary for that portion of the project.
31. No stockpiling of materials or supplies will be located within 35' of the Bordering Vegetated Wetlands on the property.
32. If disturbed areas are not permanently stabilized by the end of the growing season, the applicant must monitor the area and install or repair sediment and erosion controls to protect the resource area until the site is stabilized.
33. There shall be no refueling of equipment within 35 feet of resource areas. A spill kit shall be onsite at all times.
34. Applicant shall seek to minimize vegetation (tree and shrub) removal in the wetland.
35. All waste and excavated material shall be disposed of in accordance with applicable laws.
36. Upon completion of this project, the applicant shall submit the following to the Stow Conservation Commission to receive a Certificate of Compliance.
 - a. A letter from the applicant requesting a Certificate of Compliance.
 - b. Photographs of the boardwalk and parking area showing the completed work.

Perpetual Conditions:

35. The boardwalk shall be maintained for its useable lifespan so as to preserve its integrity. No further permitting is required for routine maintenance.



Massachusetts Department of Environmental Protection
Bureau of Resource Protection - Wetlands
WPA Form 5 – Order of Conditions
 Massachusetts Wetlands Protection Act M.G.L. c. 131, §40

Provided by MassDEP:
 299-719
 MassDEP File # _____

eDEP Transaction # _____

City/Town _____

E. Signatures

This Order is valid for three years, unless otherwise specified as a special condition pursuant to General Conditions #4, from the date of issuance.

9/27/2022

1. Date of Issuance

Please indicate the number of members who will sign this form.

4

This Order must be signed by a majority of the Conservation Commission.

2. Number of Signers

The Order must be mailed by certified mail (return receipt requested) or hand delivered to the applicant. A copy also must be mailed or hand delivered at the same time to the appropriate Department of Environmental Protection Regional Office, if not filing electronically, and the property owner, if different from applicant.

VS

~~Signature~~

~~SIRENIA FULMANT~~

Signature

Printed Name

Elizabeth Mattison

Printed Name

Signature

Printed Name

Ingeborg Hegemann Clark

Printed Name

Signature

Printed Name

Holly Clark

Printed Name

Signature

Printed Name

MATTHEW STYCKSENWICZ

Printed Name

Signature

Printed Name

Signature

Printed Name

Signature

Printed Name

by hand delivery on

by certified mail, return receipt requested, on

Date 9/27/22

Date _____



Massachusetts Department of Environmental Protection
Bureau of Resource Protection - Wetlands
WPA Form 5 – Order of Conditions
 Massachusetts Wetlands Protection Act M.G.L. c. 131, §40

Provided by MassDEP:
 299-719
 MassDEP File #

eDEP Transaction #

City/Town

F. Appeals

The applicant, the owner, any person aggrieved by this Order, any owner of land abutting the land subject to this Order, or any ten residents of the city or town in which such land is located, are hereby notified of their right to request the appropriate MassDEP Regional Office to issue a Superseding Order of Conditions. The request must be made by certified mail or hand delivery to the Department, with the appropriate filing fee and a completed Request for Departmental Action Fee Transmittal Form, as provided in 310 CMR 10.03(7) within ten business days from the date of issuance of this Order. A copy of the request shall at the same time be sent by certified mail or hand delivery to the Conservation Commission and to the applicant, if he/she is not the appellant.

Any appellants seeking to appeal the Department's Superseding Order associated with this appeal will be required to demonstrate prior participation in the review of this project. Previous participation in the permit proceeding means the submission of written information to the Conservation Commission prior to the close of the public hearing, requesting a Superseding Order, or providing written information to the Department prior to issuance of a Superseding Order.

The request shall state clearly and concisely the objections to the Order which is being appealed and how the Order does not contribute to the protection of the interests identified in the Massachusetts Wetlands Protection Act (M.G.L. c. 131, § 40), and is inconsistent with the wetlands regulations (310 CMR 10.00). To the extent that the Order is based on a municipal ordinance or bylaw, and not on the Massachusetts Wetlands Protection Act or regulations, the Department has no appellate jurisdiction.



Town of Stow Conservation Commission

380 Great Road
Stow, Massachusetts 01775-0261
(978) 897-8615 FAX (978) 897-4534
email: conservation@stow-ma.gov

STOW CONSERVATION COMMISSION NOTICE OF PUBLIC HEARING

The **Stow Conservation Commission** will hold a public hearing via Zoom web conferencing **September 20, 2022 at 7:45 pm** to consider the **Notice of Intent** filed by the **Stow Conservation Department**. The proposed activities, **grading, construction of gravel parking area, and trail and boardwalk construction**, are within an area subject to the jurisdiction of the Wetlands Protection Act, MGL CH 131, Sec. 40 and the Town of Stow Wetlands Protection Bylaw. Said activity is located on Map R30, Parcel 20 and R21, Parcel 57A off Tuttle Lane. Copies of the application and plan are on file at the Office of the Conservation Commission and posted on the Town website. Call-in instructions will be posted on the agenda and website.

STOW CONSERVATION COMMISSION
Serena Furman, Chair

Printed in the August 31, 2022 Stow Independent

Please print the above legal notice in the August 31, 2022 edition of the Stow Independent and bill as indicated below:

Stow Conservation Commission
380 Great Road
Stow, MA 01775
978-897-8615
conservation@stow-ma.gov



Massachusetts Department of Environmental Protection
Bureau of Resource Protection - Wetlands
WPA Form 3 – Notice of Intent
Massachusetts Wetlands Protection Act M.G.L. c. 131, §40

Provided by MassDEP:

MassDEP File Number _____
Document Transaction Number _____
City/Town _____

Important:
When filling out forms on the computer, use only the tab key to move your cursor - do not use the return key.



Note:
Before completing this form consult your local Conservation Commission regarding any municipal bylaw or ordinance.

A. General Information

1. Project Location (Note: electronic filers will click on button to locate project site):

Tuttle Lane & Red Acre Road
a. Street Address
Stow
b. City/Town
01775
c. Zip Code
Latitude and Longitude:
R30 and R31
d. Latitude
20 and 57A
e. Longitude
f. Assessors Map/Plat Number
g. Parcel /Lot Number

2. Applicant:

Jacque
a. First Name
Goring
b. Last Name
Town of Stow Conservation Department
c. Organization
380 Great Road
d. Street Address
Stow
e. City/Town
MA
f. State
01775
g. Zip Code
978-897-8615
h. Phone Number
i. Fax Number
conservation2@stow-ma.gov
j. Email Address

3. Property owner (required if different from applicant): Check if more than one owner

Town of Stow and Stow Conservation Trust
a. First Name
b. Last Name
c. Organization
380 Great Road
d. Street Address
Stow
e. City/Town
MA
f. State
01775
g. Zip Code
stowconservationtrust.info@gmail.com
h. Phone Number
i. Fax Number
j. Email address

4. Representative (if any):

a. First Name
b. Last Name
c. Company
d. Street Address
e. City/Town
f. State
g. Zip Code
h. Phone Number
i. Fax Number
j. Email address

5. Total WPA Fee Paid (from NOI Wetland Fee Transmittal Form):

NA, fee exempt
a. Total Fee Paid
NA, fee exempt
b. State Fee Paid
NA, fee exempt
c. City/Town Fee Paid



Massachusetts Department of Environmental Protection
Bureau of Resource Protection - Wetlands

Provided by MassDEP:

WPA Form 3 – Notice of Intent

Massachusetts Wetlands Protection Act M.G.L. c. 131, §40

MassDEP File Number

Document Transaction Number

City/Town

A. General Information (continued)

6. General Project Description:

Construction of a five car gravel parking lot at the Stow Community Gardens and construction of 360 linear feet of boardwalk to connect the Stow Community Gardens/Captain Sargent Conservation Area to Red Acre Woodlands

7a. Project Type Checklist: (Limited Project Types see Section A. 7b.)

- 1. Single Family Home
- 2. Residential Subdivision
- 3. Commercial/Industrial
- 4. Dock/Pier
- 5. Utilities
- 6. Coastal engineering Structure
- 7. Agriculture (e.g., cranberries, forestry)
- 8. Transportation
- 9. Other Municipal Trail Project

7b. Is any portion of the proposed activity eligible to be treated as a limited project (including Ecological Restoration Limited Project) subject to 310 CMR 10.24 (coastal) or 310 CMR 10.53 (inland)?

1. Yes No If yes, describe which limited project applies to this project. (See 310 CMR 10.24 and 10.53 for a complete list and description of limited project types)

2. Limited Project Type

If the proposed activity is eligible to be treated as an Ecological Restoration Limited Project (310 CMR10.24(8), 310 CMR 10.53(4)), complete and attach Appendix A: Ecological Restoration Limited Project Checklist and Signed Certification.

8. Property recorded at the Registry of Deeds for:

Southern Middlesex (Captain Sargent Conservation Area/Red Acre Woodlands/Kunelius

a. County	b. Certificate # (if registered land)
14475/35452/71090	583/112/379
c. Book	d. Page Number

B. Buffer Zone & Resource Area Impacts (temporary & permanent)

- 1. Buffer Zone Only – Check if the project is located only in the Buffer Zone of a Bordering Vegetated Wetland, Inland Bank, or Coastal Resource Area.
- 2. Inland Resource Areas (see 310 CMR 10.54-10.58; if not applicable, go to Section B.3, Coastal Resource Areas).

Check all that apply below. Attach narrative and any supporting documentation describing how the project will meet all performance standards for each of the resource areas altered, including standards requiring consideration of alternative project design or location.



Massachusetts Department of Environmental Protection
Bureau of Resource Protection - Wetlands

WPA Form 3 – Notice of Intent

Massachusetts Wetlands Protection Act M.G.L. c. 131, §40

Provided by MassDEP:

MassDEP File Number _____

Document Transaction Number _____

City/Town _____

B. Buffer Zone & Resource Area Impacts (temporary & permanent) (cont'd)

For all projects affecting other Resource Areas, please attach a narrative explaining how the resource area was delineated.

Resource Area	Size of Proposed Alteration	Proposed Replacement (if any)
a. <input type="checkbox"/> Bank	1. linear feet _____	2. linear feet _____
b. <input checked="" type="checkbox"/> Bordering Vegetated Wetland	de minimis 1. square feet _____	NA 2. square feet _____
c. Land Under Waterbodies and Waterways	1. square feet _____ 3. cubic yards dredged _____	2. square feet _____

Resource Area	Size of Proposed Alteration	Proposed Replacement (if any)
d. <input type="checkbox"/> Bordering Land Subject to Flooding	1. square feet _____ 3. cubic feet of flood storage lost _____	2. square feet _____ 4. cubic feet replaced _____
e. <input type="checkbox"/> Isolated Land Subject to Flooding	1. square feet _____ 2. cubic feet of flood storage lost _____	3. cubic feet replaced _____
f. <input type="checkbox"/> Riverfront Area	1. Name of Waterway (if available) - specify coastal or inland _____	

2. Width of Riverfront Area (check one):

- 25 ft. - Designated Densely Developed Areas only
- 100 ft. - New agricultural projects only
- 200 ft. - All other projects

3. Total area of Riverfront Area on the site of the proposed project: _____ square feet

4. Proposed alteration of the Riverfront Area:

a. total square feet _____ b. square feet within 100 ft. _____ c. square feet between 100 ft. and 200 ft. _____

5. Has an alternatives analysis been done and is it attached to this NOI? Yes No

6. Was the lot where the activity is proposed created prior to August 1, 1996? Yes No

3. Coastal Resource Areas: (See 310 CMR 10.25-10.35)

Note: for coastal riverfront areas, please complete **Section B.2.f.** above.



Massachusetts Department of Environmental Protection
Bureau of Resource Protection - Wetlands

WPA Form 3 – Notice of Intent

Massachusetts Wetlands Protection Act M.G.L. c. 131, §40

Provided by MassDEP:

MassDEP File Number _____

Document Transaction Number _____

City/Town _____

B. Buffer Zone & Resource Area Impacts (temporary & permanent) (cont'd)

Check all that apply below. Attach narrative and supporting documentation describing how the project will meet all performance standards for each of the resource areas altered, including standards requiring consideration of alternative project design or location.

Online Users:
Include your document transaction number (provided on your receipt page) with all supplementary information you submit to the Department.

<u>Resource Area</u>	<u>Size of Proposed Alteration</u>	<u>Proposed Replacement (if any)</u>
a. <input type="checkbox"/> Designated Port Areas	Indicate size under Land Under the Ocean, below	
b. <input type="checkbox"/> Land Under the Ocean	1. square feet _____ 2. cubic yards dredged _____	
c. <input type="checkbox"/> Barrier Beach	Indicate size under Coastal Beaches and/or Coastal Dunes below	
d. <input type="checkbox"/> Coastal Beaches	1. square feet _____	2. cubic yards beach nourishment _____
e. <input type="checkbox"/> Coastal Dunes	1. square feet _____	2. cubic yards dune nourishment _____
	<u>Size of Proposed Alteration</u>	<u>Proposed Replacement (if any)</u>
f. <input type="checkbox"/> Coastal Banks	1. linear feet _____	
g. <input type="checkbox"/> Rocky Intertidal Shores	1. square feet _____	
h. <input type="checkbox"/> Salt Marshes	1. square feet _____	2. sq ft restoration, rehab., creation _____
i. <input type="checkbox"/> Land Under Salt Ponds	1. square feet _____ 2. cubic yards dredged _____	
j. <input type="checkbox"/> Land Containing Shellfish	1. square feet _____	
k. <input type="checkbox"/> Fish Runs	Indicate size under Coastal Banks, inland Bank, Land Under the Ocean, and/or inland Land Under Waterbodies and Waterways, above 1. cubic yards dredged _____	
l. <input type="checkbox"/> Land Subject to Coastal Storm Flowage	1. square feet _____	

4. Restoration/Enhancement

If the project is for the purpose of restoring or enhancing a wetland resource area in addition to the square footage that has been entered in Section B.2.b or B.3.h above, please enter the additional amount here.

a. square feet of BVW _____

b. square feet of Salt Marsh _____

5. Project Involves Stream Crossings

a. number of new stream crossings _____

b. number of replacement stream crossings _____



Massachusetts Department of Environmental Protection
Bureau of Resource Protection - Wetlands

WPA Form 3 – Notice of Intent

Massachusetts Wetlands Protection Act M.G.L. c. 131, §40

Provided by MassDEP:

MassDEP File Number

Document Transaction Number

City/Town

C. Other Applicable Standards and Requirements

- This is a proposal for an Ecological Restoration Limited Project. Skip Section C and complete Appendix A: Ecological Restoration Limited Project Checklists – Required Actions (310 CMR 10.11).

Streamlined Massachusetts Endangered Species Act/Wetlands Protection Act Review

1. Is any portion of the proposed project located in **Estimated Habitat of Rare Wildlife** as indicated on the most recent Estimated Habitat Map of State-Listed Rare Wetland Wildlife published by the Natural Heritage and Endangered Species Program (NHESP)? To view habitat maps, see the *Massachusetts Natural Heritage Atlas* or go to http://maps.massgis.state.ma.us/PRI_EST_HAB/viewer.htm.

- a. Yes No **If yes, include proof of mailing or hand delivery of NOI to:**

Natural Heritage and Endangered Species Program
Division of Fisheries and Wildlife
1 Rabbit Hill Road
Westborough, MA 01581

- 8/1/2021
b. Date of map

If yes, the project is also subject to Massachusetts Endangered Species Act (MESA) review (321 CMR 10.18). To qualify for a streamlined, 30-day, MESA/Wetlands Protection Act review, please complete Section C.1.c, and include requested materials with this Notice of Intent (NOI); OR complete Section C.2.f, if applicable. *If MESA supplemental information is not included with the NOI, by completing Section 1 of this form, the NHESP will require a separate MESA filing which may take up to 90 days to review (unless noted exceptions in Section 2 apply, see below).*

- c. Submit Supplemental Information for Endangered Species Review*

1. Percentage/acreage of property to be altered:

(a) within wetland Resource Area

percentage/acreage

(b) outside Resource Area

percentage/acreage

2. Assessor's Map or right-of-way plan of site

2. Project plans for entire project site, including wetland resource areas and areas outside of wetlands jurisdiction, showing existing and proposed conditions, existing and proposed tree/vegetation clearing line, and clearly demarcated limits of work **

- (a) Project description (including description of impacts outside of wetland resource area & buffer zone)
- (b) Photographs representative of the site

* Some projects **not** in Estimated Habitat may be located in Priority Habitat, and require NHESP review (see <https://www.mass.gov/mas-endangered-species-act-mesa-regulatory-review>).

Priority Habitat includes habitat for state-listed plants and strictly upland species not protected by the Wetlands Protection Act.

** MESA projects may not be segmented (321 CMR 10.16). The applicant must disclose full development plans even if such plans are not required as part of the Notice of Intent process.



Massachusetts Department of Environmental Protection
 Bureau of Resource Protection - Wetlands
WPA Form 3 – Notice of Intent
 Massachusetts Wetlands Protection Act M.G.L. c. 131, §40

Provided by MassDEP:

MassDEP File Number

Document Transaction Number

City/Town

C. Other Applicable Standards and Requirements (cont'd)

(c) MESA filing fee (fee information available at <https://www.mass.gov/how-to/how-to-file-for-a-mesa-project-review>).
 Make check payable to "Commonwealth of Massachusetts - NHESP" and **mail to NHESP** at above address

Projects altering 10 or more acres of land, also submit:

(d) Vegetation cover type map of site

(e) Project plans showing Priority & Estimated Habitat boundaries

(f) OR Check One of the Following

1. Project is exempt from MESA review.
 Attach applicant letter indicating which MESA exemption applies. (See 321 CMR 10.14, <https://www.mass.gov/service-details/exemptions-from-review-for-projectsactivities-in-priority-habitat>; the NOI must still be sent to NHESP if the project is within estimated habitat pursuant to 310 CMR 10.37 and 10.59.)

2. Separate MESA review ongoing. a. NHESP Tracking # _____ b. Date submitted to NHESP _____

3. Separate MESA review completed.
 Include copy of NHESP "no Take" determination or valid Conservation & Management Permit with approved plan.

3. For coastal projects only, is any portion of the proposed project located below the mean high water line or in a fish run?

a. Not applicable – project is in inland resource area only b. Yes No

If yes, include proof of mailing, hand delivery, or electronic delivery of NOI to either:

South Shore - Cohasset to Rhode Island border, and the Cape & Islands:

North Shore - Hull to New Hampshire border:

Division of Marine Fisheries -
 Southeast Marine Fisheries Station
 Attn: Environmental Reviewer
 836 South Rodney French Blvd.
 New Bedford, MA 02744
 Email: dmf.envreview-south@mass.gov

Division of Marine Fisheries -
 North Shore Office
 Attn: Environmental Reviewer
 30 Emerson Avenue
 Gloucester, MA 01930
 Email: dmf.envreview-north@mass.gov

Also if yes, the project may require a Chapter 91 license. For coastal towns in the Northeast Region, please contact MassDEP's Boston Office. For coastal towns in the Southeast Region, please contact MassDEP's Southeast Regional Office.

c. Is this an aquaculture project? d. Yes No

If yes, include a copy of the Division of Marine Fisheries Certification Letter (M.G.L. c. 130, § 57).

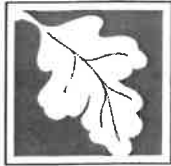

Massachusetts Department of Environmental Protection
Bureau of Resource Protection - Wetlands

Provided by MassDEP:

WPA Form 3 – Notice of Intent

Massachusetts Wetlands Protection Act M.G.L. c. 131, §40

MassDEP File Number _____

Document Transaction Number _____

City/Town _____

C. Other Applicable Standards and Requirements (cont'd)

Online Users:
 Include your document transaction number (provided on your receipt page) with all supplementary information you submit to the Department.

4. Is any portion of the proposed project within an Area of Critical Environmental Concern (ACEC)?
 a. Yes No If yes, provide name of ACEC (see instructions to WPA Form 3 or MassDEP Website for ACEC locations). **Note:** electronic filers click on Website.
 b. ACEC _____
5. Is any portion of the proposed project within an area designated as an Outstanding Resource Water (ORW) as designated in the Massachusetts Surface Water Quality Standards, 314 CMR 4.00?
 a. Yes No
6. Is any portion of the site subject to a Wetlands Restriction Order under the Inland Wetlands Restriction Act (M.G.L. c. 131, § 40A) or the Coastal Wetlands Restriction Act (M.G.L. c. 130, § 105)?
 a. Yes No
7. Is this project subject to provisions of the MassDEP Stormwater Management Standards?
 a. Yes. Attach a copy of the Stormwater Report as required by the Stormwater Management Standards per 310 CMR 10.05(6)(k)-(q) and check if:
 1. Applying for Low Impact Development (LID) site design credits (as described in Stormwater Management Handbook Vol. 2, Chapter 3)
 2. A portion of the site constitutes redevelopment
 3. Proprietary BMPs are included in the Stormwater Management System.
 b. No. Check why the project is exempt:
 1. Single-family house
 2. Emergency road repair
 3. Small Residential Subdivision (less than or equal to 4 single-family houses or less than or equal to 4 units in multi-family housing project) with no discharge to Critical Areas.

D. Additional Information

- This is a proposal for an Ecological Restoration Limited Project. Skip Section D and complete Appendix A: Ecological Restoration Notice of Intent – Minimum Required Documents (310 CMR 10.12).

Applicants must include the following with this Notice of Intent (NOI). See instructions for details.

Online Users: Attach the document transaction number (provided on your receipt page) for any of the following information you submit to the Department.

1. USGS or other map of the area (along with a narrative description, if necessary) containing sufficient information for the Conservation Commission and the Department to locate the site. (Electronic filers may omit this item.)
2. Plans identifying the location of proposed activities (including activities proposed to serve as a Bordering Vegetated Wetland [BVW] replication area or other mitigating measure) relative to the boundaries of each affected resource area.

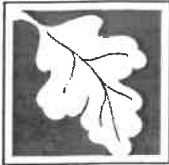

Massachusetts Department of Environmental Protection
Bureau of Resource Protection - Wetlands

Provided by MassDEP:

WPA Form 3 – Notice of Intent

Massachusetts Wetlands Protection Act M.G.L. c. 131, §40

MassDEP File Number

Document Transaction Number

City/Town

D. Additional Information (cont'd)

3. Identify the method for BVW and other resource area boundary delineations (MassDEP BVW Field Data Form(s), Determination of Applicability, Order of Resource Area Delineation, etc.), and attach documentation of the methodology.

4. List the titles and dates for all plans and other materials submitted with this NOI.

<u>Garden Entrance Concept Plan</u>	
a. Plan Title	
<u>J. Goring</u>	<u>NA</u>
b. Prepared By	c. Signed and Stamped by
<u>8/10/2022</u>	<u>Not to Scale</u>
d. Final Revision Date	e. Scale
<u>Captain Sargent Conservation Area and Red Acre Woodlands Trail Map and Design Sketch</u>	<u>8/10/2022</u>
f. Additional Plan or Document Title	g. Date

5. If there is more than one property owner, please attach a list of these property owners not listed on this form.

6. Attach proof of mailing for Natural Heritage and Endangered Species Program, if needed.

7. Attach proof of mailing for Massachusetts Division of Marine Fisheries, if needed.

8. Attach NOI Wetland Fee Transmittal Form

9. Attach Stormwater Report, if needed.

E. Fees

1. Fee Exempt: No filing fee shall be assessed for projects of any city, town, county, or district of the Commonwealth, federally recognized Indian tribe housing authority, municipal housing authority, or the Massachusetts Bay Transportation Authority.

Applicants must submit the following information (in addition to pages 1 and 2 of the NOI Wetland Fee Transmittal Form) to confirm fee payment:

<u>2. Municipal Check Number</u>	<u>3. Check date</u>
<u>4. State Check Number</u>	<u>5. Check date</u>
<u>6. Payor name on check: First Name</u>	<u>7. Payor name on check: Last Name</u>



Massachusetts Department of Environmental Protection
Bureau of Resource Protection - Wetlands

Provided by MassDEP:

WPA Form 3 – Notice of Intent

Massachusetts Wetlands Protection Act M.G.L. c. 131, §40

MassDEP File Number

Document Transaction Number

City/Town

F. Signatures and Submittal Requirements

I hereby certify under the penalties of perjury that the foregoing Notice of Intent and accompanying plans, documents, and supporting data are true and complete to the best of my knowledge. I understand that the Conservation Commission will place notification of this Notice in a local newspaper at the expense of the applicant in accordance with the wetlands regulations, 310 CMR 10.05(5)(a).

I further certify under penalties of perjury that all abutters were notified of this application, pursuant to the requirements of M.G.L. c. 131, § 40. Notice must be made by Certificate of Mailing or in writing by hand delivery or certified mail (return receipt requested) to all abutters within 100 feet of the property line of the project location.

<i>Rachel Flynn for the State Cons. Commission</i>	8/15/22
1. Signature of Applicant / Owner	2. Date
<i>Arman J. Law, VP, State Conservation Trust</i>	8/15/22
3. Signature of Property Owner (if different)	4. Date
5. Signature of Representative (if any)	6. Date

For Conservation Commission:

Two copies of the completed Notice of Intent (Form 3), including supporting plans and documents, two copies of the NOI Wetland Fee Transmittal Form, and the city/town fee payment, to the Conservation Commission by certified mail or hand delivery.

For MassDEP:

One copy of the completed Notice of Intent (Form 3), including supporting plans and documents, one copy of the NOI Wetland Fee Transmittal Form, and a **copy** of the state fee payment to the MassDEP Regional Office (see Instructions) by certified mail or hand delivery.

Other:

If the applicant has checked the "yes" box in any part of Section C, Item 3, above, refer to that section and the Instructions for additional submittal requirements.

The original and copies must be sent simultaneously. Failure by the applicant to send copies in a timely manner may result in dismissal of the Notice of Intent.



Massachusetts Department of Environmental Protection
Bureau of Resource Protection - Wetlands
NOI Wetland Fee Transmittal Form
 Massachusetts Wetlands Protection Act M.G.L. c. 131, §40

Important: When filling out forms on the computer, use only the tab key to move your cursor - do not use the return key.



A. Applicant Information

1. Location of Project:

Tuttle Lane & Red Acre Road
 a. Street Address
 NA, fee exempt
 c. Check number
 Stow
 b. City/Town
 NA, fee exempt
 d. Fee amount

2. Applicant Mailing Address:

a. First Name
 Town of Stow
 c. Organization
 380 Great Road
 d. Mailing Address
 Stow
 e. City/Town
 978-897-8615
 h. Phone Number
 MA
 f. State
 conservation2@stow-ma.gov
 j. Email Address
 01775
 g. Zip Code

3. Property Owner (if different):

a. First Name
 Town of Stow and Stow Conservation Trust
 c. Organization
 380 Great Road
 d. Mailing Address
 Stow
 e. City/Town
 MA
 f. State
 stowconservationtrust.info@gmail.com
 j. Email Address
 01775
 g. Zip Code

B. Fees

Fee should be calculated using the following process & worksheet. **Please see Instructions before filling out worksheet.**

Step 1/Type of Activity: Describe each type of activity that will occur in wetland resource area and buffer zone.

Step 2/Number of Activities: Identify the number of each type of activity.

Step 3/Individual Activity Fee: Identify each activity fee from the six project categories listed in the instructions.

Step 4/Subtotal Activity Fee: Multiply the number of activities (identified in Step 2) times the fee per category (identified in Step 3) to reach a subtotal fee amount. Note: If any of these activities are in a Riverfront Area in addition to another Resource Area or the Buffer Zone, the fee per activity should be multiplied by 1.5 and then added to the subtotal amount.

Step 5/Total Project Fee: Determine the total project fee by adding the subtotal amounts from Step 4.

Step 6/Fee Payments: To calculate the state share of the fee, divide the total fee in half and subtract \$12.50. To calculate the city/town share of the fee, divide the total fee in half and add \$12.50.

To calculate filing fees, refer to the category fee list and examples in the instructions for filling out WPA Form 3 (Notice of Intent).

Town of Stow – Stow Conservation Commission

Notice of Intent – Tuttle Lane & Red Acre Road – Captain Sargent Conservation Area

Parking Area and Boardwalk

The Town of Stow Conservation Commission proposes two improvements to the town-owned Captain Sargent Conservation Area.

The first project will include construction of a five car gravel parking area located within 100' of bordering vegetated wetlands (BVW). The parking lot will be located at least 35 feet from wetlands at its closest point. Two farm gates on either side of the parking lot will be installed on the Community Garden road to limit vehicle traffic to gardener vehicles only.

The second project is to construct 360 linear feet of boardwalk to connect Captain Sargent Conservation Area and Red Acre Woodlands. The proposed boardwalk will be constructed using pipe augers and wood decking. The use of pipe augers will result in only de minimis alteration of bordering vegetated wetland and will not result in fill. The boardwalk will be four feet wide and constructed in eight-foot spans. All construction work will be done by hand and materials will be brought to the work area manually. A truck may be driven into the trail head behind the Community Gardens to bring materials as close as possible to the worksite. The wetland is well defined using plant and soil characteristics. The boardwalk work will be done during winter or dry conditions.

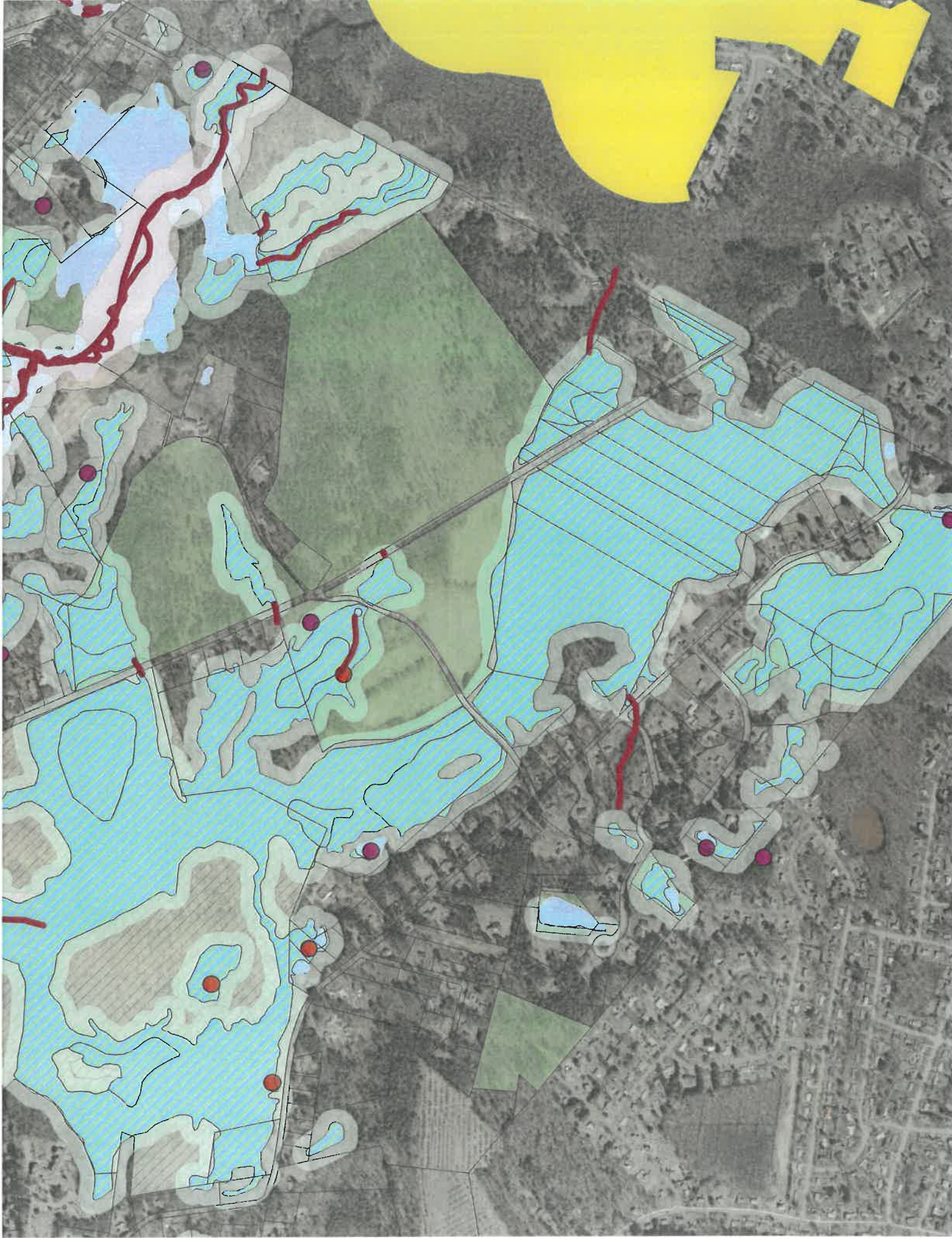

Garden Entrance Concept Plan

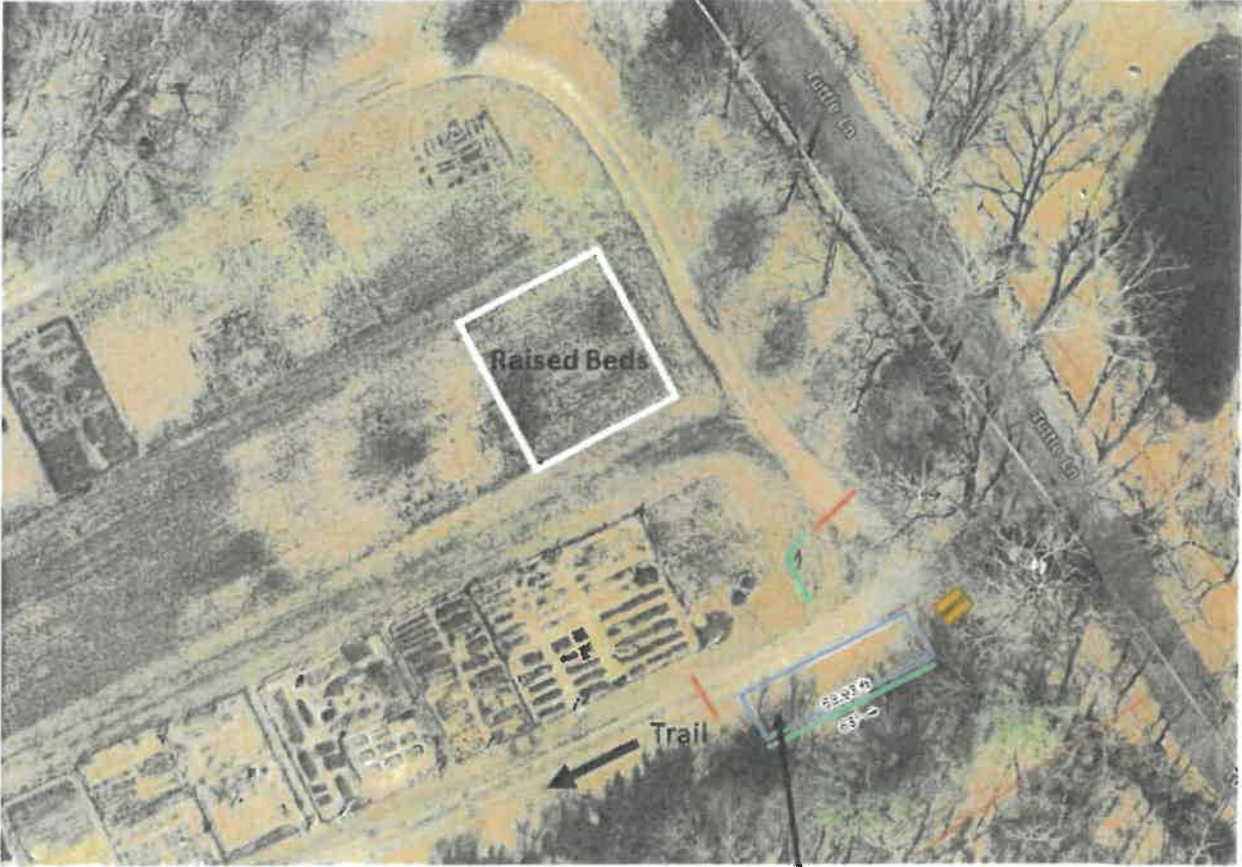

— Garden Road Gates
— Rocks

Existing Kiosk

Parking

J. Gannig
8/10/2022

Area Maps - Showing Significance of Trail Connection (Red Circle is Trail Gap)

Captain Sargent Conservation Area and Red Acre Woodlands



8/10/2022

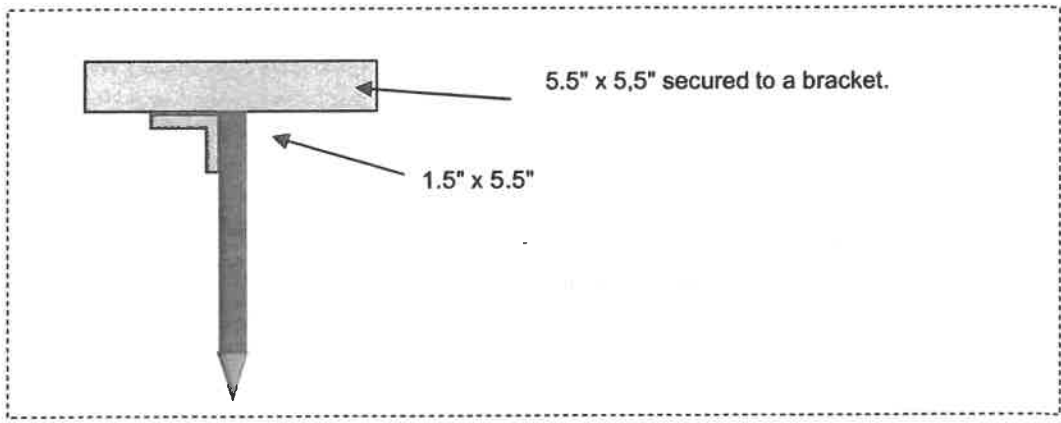
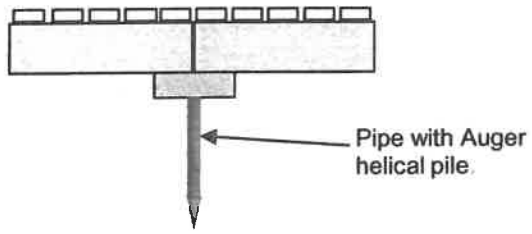
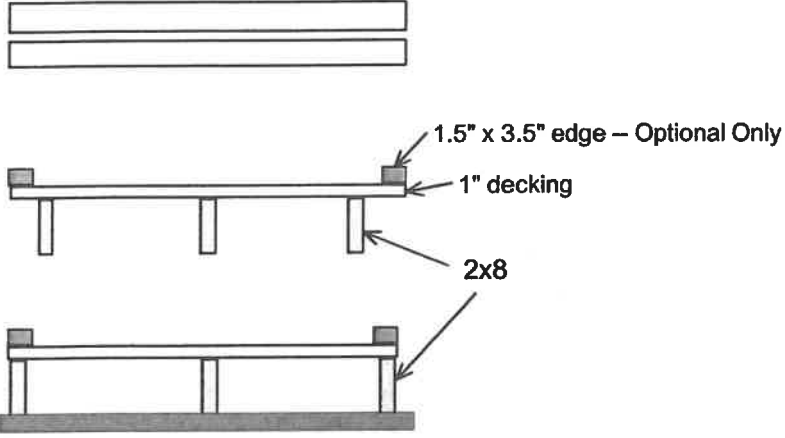
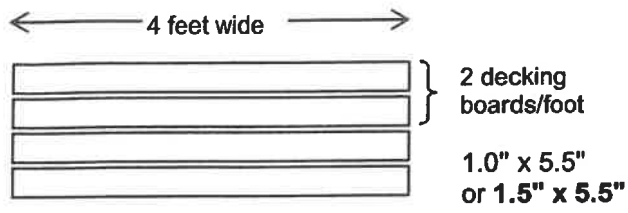

Town of Stow Conservation Commission

Form W Request for Waiver Stow Wetlands Bylaw & Regulations

Date: 8/10/2022

Name: Town of Stow

Telephone: 978-897-8615

Mailing Address: 380 Great Road, Stow, MA 01775

Location of Work: Tuttle Lane & Red Acre Road

Map & Parcel: R30/20 & R31/57A

Section 4.5 of the Stow Wetlands Regulations state that "strict compliance with any of these Regulations for the Bylaw may be waived when, in the opinion of the Commission, such action is in the public interest and is consistent with the intent and purpose of the Bylaw."

Waiver(s) Requested:

Waiver to the 35' no disturb buffer

Reason for Requesting Waiver(s) Construction of a trail boardwalk over a wetland

Construction of a trail boardwalk over a wetland

Explanation of how the grant of the waiver is in the public interest and consistent with the intent and purposes of the Bylaw:

The proposed boardwalk will connect the Stow Community Gardens/Captain Sargent Conservation Area to Red Acre Woodlands completing a key missing trail piece connecting many miles of trails - from Flagg Hill to Lower Village - for all trail users.

ABUTTERS LIST

R31/57A AND R30/20

MAP/PARCEL	PROPERTY LOCATION	OWNER NAME 1	OWNER NAME 2	MAILING ADDRESS	CITY	STATE	ZIP CODE	DEED BOOK	DEED PAGE
00R-21 000039	0 SOUTH ACTON RD	BROWN TIFFANY		28 SOUTH ACTON ROAD	STOW	MA	01775	70456	347
00R-21 000040	58 SOUTH ACTON RD	ALEXSON ERIC	ALEXSON KATIE	58 SOUTH ACTON RD	STOW	MA	01775	66950	127
00R-21 000041	62 SOUTH ACTON RD	GIOVINO, MARIA		62 SOUTH ACTON RD	STOW	MA	01775	75414	107
00R-21 000043	0 SOUTH ACTON RD	TOWN OF STOW	CONSERVATION COMMISSION	380 GREAT ROAD	STOW	MA	01775	14475	581
00R-21 000044	0 SOUTH ACTON RD	PILOT GROVE FARM INC		P O BOX 18	STOW	MA	01775	23045	129
00R-21 00042A	88 SOUTH ACTON RD	TOWN OF STOW	HIGHWAY DEPT	380 GREAT RD	STOW	MA	01775	12008	236
00R-21 0042-1	30 WETHERBEE LN	YEE CHANG	YEE CINDY CHAO	30 WETHERBEE LANE	STOW	MA	01775	32129	296
00R-21 0042-2	98 SOUTH ACTON RD	VOGEL GREGORY A	VOGEL RACHELLE L	98 SOUTH ACTON RD	STOW	MA	01775	30675	107
00R-21 0042-3	106 SOUTH ACTON RD	FREEDMAN, MICHAEL		106 SOUTH ACTON RD	STOW	MA	01775	74711	540
00R-21 0042-4	110 SOUTH ACTON RD	SUPINSKI WALTER A	ESTHER R SUPINSKI	110 SOUTH ACTON RD	STOW	MA	01775	12263	22
00R-21 0042-5	116 SOUTH ACTON RD	HUS JEAN-CHRISTOPHE	E21:E25	116 SOUTH ACTON RD	STOW	MA	01775	71215	252
00R-21 0042-6	122 SOUTH ACTON RD	HATCH NICHOLAS	HATCH ADRIENNE	122 SOUTH ACTON RD	STOW	MA	01775	49426	341
00R-21 0042-7	128 SOUTH ACTON RD	THOMANN ULRICH H	THOMANN-STANGE NICOLE	128 SOUTH ACTON RD	STOW	MA	01775	63438	74
00R-21 042-9A	0 SOUTH ACTON RD	FLETCHER BRUCE		PO BOX 2	STOW	MA	01775	26326	145
00R-30 000009	51 SAMUEL PRESCOTT DR	CROWELL FAMILY IRREVOCABLE TRUST	CROWELL DAVID C & JOSEPHINE C	51 SAMUEL PRESCOTT DR	STOW	MA	01775	57640	70
00R-30 000010	45 SAMUEL PRESCOTT DR	DETSCH PHILIP J	MARY E DETSCH	45 SAMUEL PRESCOTT DR	STOW	MA	01775	11822	455
00R-30 000011	0 SAMUEL PRESCOTT DR	CROWELL RALPH E JR	DAVID C CROWELL T/C	17 OAK ROAD	LITTLETON	MA	01460	11946	179
00R-30 000017	30 SAMUEL PRESCOTT DR	CORRIVEAU-NELSON MARTHA	WALRATH DAVID E	30 SAMUEL PRESCOTT DRIVE	STOW	MA	01775	31881	575
00R-30 000018	40 SAMUEL PRESCOTT DR	WHITEHEAD MARK W	BRANSCOMB DIANE M	40 SAMUEL PRESCOTT DR	STOW	MA	01775	27383	441
00R-30 000019	68 RED ACRE RD	ABATISIS CHRISTOPHER		68 RED ACRE RD	STOW	MA	01775	64002	538
00R-30 00001F	5 FAXON DR	BLACKKEY I KATHERINE		5 FAXON DR	STOW	MA	01775	44653	88
00R-30 000020	0 SOUTH ACTON RD	STOW CONSERVATION TRUST, INC.		PO BOX 397	STOW	MA	01775	35452	112
00R-30 000021	118 RED ACRE RD	LEONARD CATHERINE C		118 RED ACRE RD	STOW	MA	01775	44375	269
00R-30 000022	124 RED ACRE RD	MACDONALD MOIRA E		124 RED ACRE RD	STOW	MA	01775	45140	471
00R-30 000023	130 RED ACRE RD	CHRISTIANSON PETER R	FURMAN SERENA F	130 RED ACRE ROAD	STOW	MA	01775	30192	18
00R-30 000024	134 RED ACRE RD	LABOSKY MICHAEL R		134 RED ACRE ROAD	STOW	MA	01775	71335	472
00R-30 000025	142 RED ACRE RD	JOSEPH, BRIAN J.	JOSEPH, ANGELA D.	142 RED ACRE RD	STOW	MA	01775	74793	95
00R-30 000026	148 RED ACRE RD	POLIN MARK P	POLIN PATRICIA M	148 RED ACRE ROAD	STOW	MA	01775	31777	58
00R-30 000027	154 RED ACRE RD	SOKOL, ETHAN SAMUEL	FONG, KRISTINE ELIZABETH	154 RED ACRE RD	STOW	MA	01775	76692	305
00R-30 000028	160 RED ACRE RD	TERELLA CHRISTOPHER JOHN	TERELLA ROSEMARY ANN	160 RED ACRE RD	STOW	MA	01775	63954	188
00R-30 000029	166 RED ACRE RD	LOUGHLIN, SHAUN D.	ERCOLANO, ALLISON SUE	166 RED ACRE RD	STOW	MA	01775	77541	201
00R-30 00002F	7 FAXON DR	MARSHALL MICHAEL J	MARSHALL JANET M	7 FAXON DR	STOW	MA	01775	44379	124
00R-30 000036	144 RED ACRE RD	STOW MUNICIPAL AFFORDABLE HOUSING TR	KOPCZYNSKI M, CLARK I, PAPANASTASSIOU C	380 GREAT ROAD	STOW	MA	01775	71090	375
00R-30 00003F*	9 FAXON DR	STALEY, MARY H. (TRUSTEE)	MARY H. STALEY TRUST	9 FAXON DRIVE	STOW	MA	01775	79524	494
00R-30 000044	129 RED ACRE RD	QUINN, DAVID J. & LIVNE, SHIR J. (TTEES)	THE 2021 QUINNSYLVANIA TRUST	129 RED ACRE ROAD	STOW	MA	01775	78583	354
00R-30 000045	121 RED ACRE RD	DUNN JOHN E	LEONTINE S DUNN	P O BOX 219	MAYNARD	MA	01754	11123	386
00R-30 000047	93 RED ACRE RD	SHARKEY MAXWELL J	SHARKEY STACI	93 RED ACRE RD	STOW	MA	01775	71241	513
00R-30 000049	0 RED ACRE RD	MIKOSKI LINDA		PO BOX 255	STOW	MA	01775	34168	527
00R-30 00004F	11 FAXON DR	CUMMINGS KATHLEEN M		11 FAXON DR	STOW	MA	01775	44474	453
00R-30 000050	89 RED ACRE RD	ORRELL JOHANNA A		89 RED ACRE RD	STOW	MA	01775	30654	403
00R-30 000051	85 RED ACRE RD	BURKE PHILIP J		85 RED ACRE RD	STOW	MA	01775	71237	38
00R-30 000052	79 RED ACRE RD	EGAN SUSAN E	EGAN ROBERT C	79 RED ACRE RD	STOW	MA	01775	62510	593
00R-30 000053	75 RED ACRE RD	HARMON PAT SPENCER	HARMON LINDA D	75 RED ACRE RD	STOW	MA	01775	41588	227
00R-30 000054	71 RED ACRE RD	MCMANUS, PETER	MCMANUS, NANCY J.	71 RED ACRE RD	STOW	MA	01775	76538	586
00R-30 000055	69 RED ACRE RD	DOOLEY CHRISTOPHER FOLTS	ZUCCO ANNETTE S	69 RED ACRE RD	STOW	MA	01775	64568	22

Certified by the Stow Board of Assessors:

Stuart Carter, MAA

Date Certified or Re-Certified:

8/8/22 Ft: 300 -

R31/57A AND R30/20

00R-30 00005F	12	FAXON DR	BENOIT BEVERLY L REVOCABLE TRUST	BENOIT BEVERLY L TRUSTEE	12 FAXON DR	STOW	MA	01775	57193	54
00R-30 00006F	14	FAXON DR	KILMARTIN KAREN		PO BOX 684	STOW	MA	01775	53546	78
00R-30 00007F	16	FAXON DR	PROVENCHER NORMAND L	LANKFORD BARBARA	16 FAXON DRIVE	STOW	MA	01775	65543	206
00R-30 00008F	18	FAXON DR	COTTER, BRENDAN M. & BRIAN H. (TTEES)	SGC IRREVOCABLE TRUST	18 FAXON DR	STOW	MA	01775	71691	476
00R-30 00009F	24	FAXON DR	SELF, CARY	BOTT, STEPHANIE	24 FAXON DR	STOW	MA	01775	78555	147
00R-30 0000A1*	34	MEETING HOUSE LN	KILKENNY, ROBERT (TRUSTEE)	LUCILLE M. KILKENNY IRR. TRUST	92 ADAMS DR	STOW	MA	01775	80139	559
00R-30 0000A2	34	MEETING HOUSE LN	YANG, HAIYING		34 MEETING HOUSE LN, #211	STOW	MA	01775	75010	485
00R-30 0000A3	34	MEETING HOUSE LN	HELANDER, ROY		34 MEETING HOUSE LN, #219	STOW	MA	01775	788806	331
00R-30 0000A4	34	MEETING HOUSE LN	CARR INVESTMENT TRUST	CARR JANET E TRUSTEE	34 MEETING HOUSE LN, #111	STOW	MA	01775	63442	54
00R-30 0000A5	34	MEETING HOUSE LN	OLD MARLBORO ROAD REALTY TRUST	JOHNSON JANE A TRUSTEE	34 MEETING HOUSE LN, #110	STOW	MA	01775	71191	128
00R-30 0000A6	34	MEETING HOUSE LN	SOMERS, HARRIET P., BOZEK, THOMAS E. & L	HARRIET P. SOMERS LIVING TRUST	34 MEETING HOUSE LN, #310	STOW	MA	01775	74364	385
00R-30 0000A7	34	MEETING HOUSE LN	WEAVER KATHLEEN M		23 MEETING HOUSE LN, #117	STOW	MA	01775	61204	308
00R-30 0000A8	34	MEETING HOUSE LN	KANTER STEPHEN G	KANTER KAREN E	34 CORTLAND DR	STOW	MA	01775	68559	448
00R-30 0000A9	34	MEETING HOUSE LN	TEDESCO THEODORE M		108 FORD RD	SUDBURY	MA	01776	72578	228
00R-30 0000G2	0	FAXON DR	MARSHALL MICHAEL J	MARSHALL JANET M	7 FAXON DR	STOW	MA	01775	44379	128
00R-30 0000G3*	0	FAXON DR	STALEY, MARY H. (TRUSTEE)	MARY H. STALEY TRUST	9 FAXON DRIVE	STOW	MA	01775	79524	499
00R-30 0000G4	0	FAXON DR	CUMMINGS KATHLEEN M		11 FAXON DR	STOW	MA	01775	44474	457
00R-30 0000G5	0	FAXON DR	BENOIT BEVERLY L REVOCABLE TRUST	BENOIT BEVERLY LEWIS	12 FAXON DR	STOW	MA	01775	57193	58
00R-30 0000G6	0	FAXON DR	KILMARTIN PETER J		PO BOX 684	STOW	MA	01775	44781	487
00R-30 0000G7	0	FAXON DR	PROVENCHER NORMAND L	BARBARA LANKFORD	16 FAXON DR	STOW	MA	01775	65543	211
00R-30 0000G8	0	FAXON DR	COTTER, BRENDAN M. & BRIAN H. (TTEES)	SGC IRREVOCABLE TRUST	18 FAXON DR	STOW	MA	01775	71691	480
00R-30 0000G9	0	FAXON DR	SELF, CARY	BOTT, STEPHANIE	24 FAXON DR	STOW	MA	01775	78555	147
00R-30 000102	34	MEETING HOUSE LN	HOWARTH, SUSAN		34 MEETING HOUSE LN, #102	STOW	MA	01775	79284	62
00R-30 000103	34	MEETING HOUSE LN	TSAO MARGARET ONG		34 MEETING HOUSE LN, #103	STOW	MA	01775	56734	167
00R-30 000104	34	MEETING HOUSE LN	34 MEETING HOUSE LANE REALTY TRUST	LUCIANO LOUIS S TRUSTEE; FRANCES J TRUST	34 MEETING HOUSE LN, #104	STOW	MA	01775	43125	273
00R-30 000105*	34	MEETING HOUSE LN	WILBER, ISABEL C. & ROBERT T. (TTEES)	ISABEL C. WILBER LIVING TRUST	34 MEETING HOUSE LN, #105	STOW	MA	01775	79641	331
00R-30 000106	34	MEETING HOUSE LN	CYR MADELINE O LIVING TRUST	CYR MADELINE O, FRED E OLIVER,, DEBRA LAL	34 MEETING HOUSE LN, #106	STOW	MA	01775	70860	104
00R-30 000107	34	MEETING HOUSE LN	CARDARELLI, ANDREA M.		34 MEETING HOUSE LN, #107	STOW	MA	01775	77835	281
00R-30 000108*	34	MEETING HOUSE LN	BOWN, ELIZABETH	BOWN, ALFRED	34 MEETING HOUSE LN, #108	STOW	MA	01775	80054	145
00R-30 000109	34	MEETING HOUSE LN	LINK JOHN H JR		34 MEETING HOUSE LN, #109	STOW	MA	01775	66771	404
00R-30 00010F	26	FAXON DR	JONES, RITA P.	JONES, LAURIE R.	26 FAXON DR	STOW	MA	01775	75422	173
00R-30 000110	34	MEETING HOUSE LN	OLD MARLBORO ROAD REALTY TRUST	JOHNSON JANE A TRUSTEE	34 MEETING HOUSE LN, #110	STOW	MA	01775	71191	123
00R-30 000111	34	MEETING HOUSE LN	CARR INVESTMENT TRUST	CARR JANET E TRUSTEE	34 MEETING HOUSE LN, #111	STOW	MA	01775	63442	54
00R-30 000113	34	MEETING HOUSE LN	STUHR JUDITH I		34 MEETING HOUSE LN, #113	STOW	MA	01775	38608	182
00R-30 000114	34	MEETING HOUSE LN	HUNT HELEN D TR	HELEN D HUNT RE TRUST	510 REVERE BEACH BLVD	REVERE	MA	02151	36166	151
00R-30 000115	34	MEETING HOUSE LN	WESLEY NEWTON P	WESLEY DOLORES M	34 MEETING HOUSE LN, #115	STOW	MA	01775	38522	456
00R-30 000116	34	MEETING HOUSE LN	HORNE GERALD A	HORNE JOANNE C	34 MEETING HOUSE LN, #116	STOW	MA	01775	51237	125
00R-30 000117	34	MEETING HOUSE LN	WEAVER KATHLEEN M		34 MEETING HOUSE LN, #117	STOW	MA	01775	61204	303
00R-30 000118	34	MEETING HOUSE LN	STUTZ NAN	STUTZ CARL	60 THOREAU ST, #360	CONCORD	MA	01742	36200	138
00R-30 000119	34	MEETING HOUSE LN	BURNS JOAN H		34 MEETING HOUSE LN, #119	STOW	MA	01775	59162	1
00R-30 00011F	28	FAXON DR	LYNCH EDMUND P	LYNCH GERALDINE D	28 FAXON DR	STOW	MA	01775	49233	162
00R-30 000120	34	MEETING HOUSE LN	MAZARES FAMILY TRUST	MAZARES GREGORY J TRUSTEE	34 MEETING HOUSE LN, #120	STOW	MA	01775	70392	34
00R-30 000121	34	MEETING HOUSE LN	DECKER MARGARET	O'CONNOR SANDRA A & BRIAN J	34 MEETING HOUSE LN, #121	STOW	MA	01775	66373	102
00R-30 00012F	30	FAXON DR	HOWE, T. JEFFREY (TRUSTEE)	T. JEFFREY HOWE TRUST	30 FAXON DRIVE	STOW	MA	01775	72138	492
00R-30 00013A	117	GREAT RD	LINEAR RETAIL STOW #1 LLC		ONE BURLINGTON WOODS DR	BURLINGTON	MA	01803	44697	52
00R-30 00013F	189	GREAT RD	CORKERY PEGGY D		189 GREAT ROAD UNIT 20	STOW	MA	01775	47555	464
00R-30 00014F	189	GREAT RD	BAUER LUIS A	BAUER-RIOFRIO ANGELICA S	189 GREAT RD #22	STOW	MA	01775	62944	550

Certified by the Stow Board of Assessors:

Stuart Carter, MAA

Date Certified or Re-Certified:

8/8/22

Ft:

300-

ABUTTERS LIST

R31/57A AND R30/20

00R-30 00015F	183	GREAT RD	STEEP & DEEP LLC		PO BOX 844	STOW	MA	01775	51172	457
00R-30 00018A	0	SAMUEL PRESCOTT DR	LINEAR RETAIL STOW #1 LLC		ONE BURLINGTON WOODS DR	BURLINGTON	MA	01803	44697	52
00R-30 000201	34	MEETING HOUSE LN	BANNON, LISA M.		34 MEETING HOUSE LN, #201	STOW	MA	01775	78650	450
00R-30 000202*	34	MEETING HOUSE LN	MOORE, EDWARD	MOORE, DELIA	14907 BOWFIN TER	LAKEWOOD RANCH	FL	34202	79799	429
00R-30 000203	34	MEETING HOUSE LN	MOULTON KARIN N	MARSHALL LAURA M	34 MEETING HOUSE LN, #203	STOW	MA	01775	68898	312
00R-30 000204	34	MEETING HOUSE LN	ZORAN SPASOJEVIC		34 MEETING HOUSE LN, #204	STOW	MA	01775	73442	396
00R-30 000205	34	MEETING HOUSE LN	KATZ, JONATHAN S. (TRUSTEE)	KATZ FAMILY TRUST	34 MEETING HOUSE LN, #205	STOW	MA	01775	78744	35
00R-30 000206	34	MEETING HOUSE LN	EAKMAN GREGORY T	EAKMAN DOREEN R M	1 TODD LN	BILLERICA	MA	01821	59246	259
00R-30 000207	34	MEETING HOUSE LN	PETITO JOANNE REVOCABLE TR OF 2013	PETITO JOANNE TRUSTEE	34 MEETING HOUSE LN, #207	STOW	MA	01775	61732	532
00R-30 000208	34	MEETING HOUSE LN	CRONIS PAUL		34 MEETINGHOUSE LN, #208	STOW	MA	01775	72792	122
00R-30 000209	34	MEETING HOUSE LN	BAKER SHARYN D		34 MEETING HOUSE LN, #209	STOW	MA	01775	72689	483
00R-30 000210*	34	MEETING HOUSE LN	KILKENNY, ROBERT (TRUSTEE)	LUCILLE M. KILKENNY IRR. TRUST	92 ADAMS DR	STOW	MA	01775	80139	559
00R-30 000211	34	MEETING HOUSE LN	YANG, HAIYING		34 MEETING HOUSE LN, #211	STOW	MA	01775	75010	485
00R-30 000212	34	MEETING HOUSE LN	PUCHOVSKY, MILOSH T. (TRUSTEE)	BOZENA PUCHOVSKY 2021 IRREV TRUST	34 MEETING HOUSE LN, #212	STOW	MA	01775	79072	268
00R-30 000213	34	MEETING HOUSE LN	WILLIAMS FREDERIC		14 STONEBROOK RD	SUDBURY	MA	01776	57045	195
00R-30 000214	34	MEETING HOUSE LN	BROWN JANE ANN		34 MEETING HOUSE LN, #214	STOW	MA	01775	55186	340
00R-30 000215	34	MEETING HOUSE LN	JONES ELSIE		34 MEETING HOUSE LN, #215	STOW	MA	01775	70010	169
00R-30 000216	34	MEETING HOUSE LN	AFK REALTY TRUST	C/O ANNETTE KIDDIE	34 MEETING HOUSE LN, #216	STOW	MA	01775	39385	261
00R-30 000217	34	MEETING HOUSE LN	CREAMER, ANNE M.		34 MEETING HOUSE LN, #217	STOW	MA	01775	79018	519
00R-30 000218	34	MEETING HOUSE LN	MCMORROW ALICE B -- LE	MCMORROW MAUREEN P	34 MEETING HOUSE LN, #218	STOW	MA	01775	71307	311
00R-30 000219	34	MEETING HOUSE LN	HELANDER, ROY		34 MEETING HOUSE LN, #219	STOW	MA	01775	78806	331
00R-30 000220	34	MEETING HOUSE LN	FITZPATRICK, LYNN		34 MEETING HOUSE LN, #220	STOW	MA	01775	79273	86
00R-30 000221	34	MEETING HOUSE LN	SIMAS DALIA J		34 MEETING HOUSE LN, #221	STOW	MA	01775	72342	157
00R-30 000301	34	MEETING HOUSE LN	TEDESCO THEODORE M		108 FORD RD	SUDBURY	MA	01776	72578	228
00R-30 000302	34	MEETING HOUSE LN	NADRLJANSKI GORDANA		34 MEETING HOUSE LN, #302	STOW	MA	01775	72556	442
00R-30 000303	34	MEETING HOUSE LN	HOWLETT SERENA		34 MEETING HOUSE LN, #303	STOW	MA	01775	61097	98
00R-30 000304*	34	MEETING HOUSE LN	MORGAN, MAUREEN K.	MORGAN, MAUREEN K.	34 MEETING HOUSE LN, #304	STOW	MA	01775	79525	159
00R-30 000305	34	MEETING HOUSE LN	TOOMEY, CAROL M. (TTEE)	THE MARY BATSTONE 2003 TRUST	43 SYLVAN DR	STOW	MA	01775	77743	333
00R-30 000306	34	MEETING HOUSE LN	DUHAMEL REALTY TRUST	HENRY & CLAUDETTE DUHAMEL TTEES	34 MEETING HOUSE LN, #306	STOW	MA	01775	73439	115
00R-30 000307	34	MEETING HOUSE LN	WOLFE CYNTHIA LOUISE		34 MEETING HOUSE LN, #307	STOW	MA	01775	72896	287
00R-30 000308	34	MEETING HOUSE LN	CONANT RICHARD K	PATTON MARTHA F L	34 MEETING HOUSE LN, #308	STOW	MA	01775	54829	393
00R-30 000309	34	MEETING HOUSE LN	KATZ, HILLARY		3 CHEROKEE RD	ACTON	MA	01720	79075	443
00R-30 000310	34	MEETING HOUSE LN	SOMERS, HARRIET P., BOZEK, THOMAS E. & LY	HARRIET P. SOMERS LIVING TRUST	34 MEETING HOUSE LN, #310	STOW	MA	01775	74364	380
00R-30 000311	34	MEETING HOUSE LN	WHEELER ALLEN	WHEELER MARTHA	34 MEETING HOUSE LN, #311	STOW	MA	01775	71947	410
00R-30 000312	34	MEETING HOUSE LN	DEARBORN DAISY THE FAMILY TRUST	HELEN HALLORAN TRUSTEE	34 MEETING HOUSE LN, #312	STOW	MA	01775	67466	330
00R-30 000313	34	MEETING HOUSE LN	PENEZIC, AROL P.	PENEZIC JR., THEODORE C.	34 MEETING HOUSE LN, #313	STOW	MA	01775	76227	573
00R-30 000314	34	MEETING HOUSE LN	JANET & SUSAN SHANNON	CAROLYN & NEAL OPALKA	34 MEETING HOUSE LN, #314	STOW	MA	01775	73852	33
00R-30 000315	34	MEETING HOUSE LN	LOHANICK, JESSICA L.		965 SOUTH EASTVIEW DR	FAYETTEVILLE	AR	72701	51950	315
00R-30 000316	34	MEETING HOUSE LN	CONSTANTZOS HECTOR		34 MEETING HOUSE LN, #316	STOW	MA	01775	69795	351
00R-30 000317	34	MEETING HOUSE LN	WALSH JUDITH A		34 MEETING HOUSE LN, #317	STOW	MA	01775	39873	24
00R-30 000318	34	MEETING HOUSE LN	HANSON, MARILYN S. & DIANE H. HAYES (TTEE)	MARILYN S. HANSEN LIVING TRUST	34 MEETING HOUSE LN, #318	STOW	MA	01775	79059	95
00R-30 000319	34	MEETING HOUSE LN	PURINTON MARCH G & MARION C. (LE)	HANSEN KAREN & PURINTON CARL & DAVID M	34 MEETING HOUSE LN, #319	STOW	MA	01775	55514	256
00R-30 000320	34	MEETING HOUSE LN	BENEDICT JOHN P	BENEDICT ELEANOR A	68 SHORE DRIVE	CONCORD	MA	01742	39020	622
00R-30 000321	34	MEETING HOUSE LN	ALEXSON, SARAH A., TTEE	ALEXSON REALTY TRUST	34 MEETING HOUSE LN, #321	STOW	MA	01775	76138	126
00R-30 00046A	109	RED ACRE RD	BROOKLINE INFANT-TODDLER CENTER INC		1900 COMMONWEALTH AVE	NEWTON	MA	02166	67351	496
00R-30 000A10	34	MEETING HOUSE LN	WOLFE CYNTHIA LOUISE		34 MEETING HOUSE LN, #307	STOW	MA	01775	72896	287
00R-30 000A11	34	MEETING HOUSE LN	BAKER SHARYN D		34 MEETINGHOUSE LN, #209	STOW	MA	01775	72689	488

Certified by the Stow Board of Assessors:

Stuart Carter
Stuart Carter, MAA

Date Certified or Re-Certified:

8/8/22

Ft:

300

R31/57A AND R30/20

00R-30 000A12	34	MEETING HOUSE LN	WHEELER ALLEN	WHEELER MARTHA	34 MEETING HOUSE LN, #311	STOW	MA	01775	71947	448
00R-30 000B13	34	MEETING HOUSE LN	BANNON, LISA M.		34 MEETING HOUSE LN, #201	STOW	MA	01775	78650	450
00R-30 000B14	34	MEETING HOUSE LN	KATZ, JONATHAN S. (TRUSTEE)	KATZ FAMILY TRUST	34 MEETING HOUSE LN, #205	STOW	MA	01775	78744	35
00R-30 000B15	34	MEETING HOUSE LN	BENEDICT JOHN P	BENEDICT ELEANOR A	68 SHORE DRIVE	CONCORD	MA	01742	39021	1
00R-30 000B16*	34	MEETING HOUSE LN	MOORE, EDWARD	MOORE, DELIA	14907 BOWFIN TER	LAKEWOOD RANCH	FL	34202	79799	429
00R-30 000C17	34	MEETING HOUSE LN	MCMORROW ALICE B -- LE	MCMORROW MAUREEN P	34 MEETING HOUSE LN, #218	STOW	MA	01775	71307	311
00R-30 000C18	34	MEETING HOUSE LN	CONSTANTZOS HECTOR		34 MEETING HOUSE LN, #316	STOW	MA	01775	69795	357
00R-30 000C19	34	MEETING HOUSE LN	HORNE GERALD A	HORNE JOANNE C	34 MEETING HOUSE LN, #116	STOW	MA	01775	51237	129
00R-30 000C20	34	MEETING HOUSE LN	BROWN JANE ANN		34 MEETING HOUSE LN, #214	STOW	MA	01775	55186	342
00R-30 000C21	34	MEETING HOUSE LN	NADRLJANSKI GORDANA		34 MEETING HOUSE LN, #302	STOW	MA	01775	72556	445
00R-30 000C22	34	MEETING HOUSE LN	PURINTON MARCH G & MARION C LE	HANSON KAREN & CARL M & DAVID N PURIN	34 MEETING HOUSE LN, #319	STOW	MA	01775	55514	256
00R-30 000C23	34	MEETING HOUSE LN	KATZ, HILLARY		3 CHEROKEE RD	ACTON	MA	01720	79075	448
00R-30 000C24	34	MEETING HOUSE LN	PENEZIC, AROL P.	PENEZIC JR., THEODORE C.	34 MEETING HOUSE LN, #313	STOW	MA	01775	76227	581
00R-30 000D25	34	MEETING HOUSE LN	EAKMAN STEPHEN L		1 TODD LN	BILLERICA	MA	01821	21000	0
00R-30 000D26	34	MEETING HOUSE LN	AFK REALTY TRUST	C/O ANNETTE KIDDIE	34 MEETING HOUSE LN, #216	STOW	MA	01775	39385	266
00R-30 000D27*	34	MEETING HOUSE LN	WILBER, ISABEL C. & ROBERT T. (TTEES)	ISABEL C. WILBER LIVING TRUST	34 MEETING HOUSE LN, #105	STOW	MA	01775	79641	331
00R-30 000D28	34	MEETING HOUSE LN	FITZPATRICK, LYNN		34 MEETING HOUSE LN, #220	STOW	MA	01775	79273	86
00R-30 000D29	34	MEETING HOUSE LN	TOOMEY, CAROL M. (TTEE)	THE MARY BATSTONE 2003 TRUST	43 SYLVAN DR	STOW	MA	01775	77743	333
00R-30 000D30	34	MEETING HOUSE LN	CONANT RICHARD K	PATTON MARTHA F L	34 MEETING HOUSE LN, #308	STOW	MA	01775	63216	463
00R-30 000D31	34	MEETING HOUSE LN	CARDARELLI, ANDREA M.		34 MEETING HOUSE LN, #107	STOW	MA	01775	77835	275
00R-30 000D32	34	MEETING HOUSE LN	LUCIANO LOUIS S	LUCIANO FRANCES J	34 MEETING HOUSE LN, #104	STOW	MA	01775	38710	389
00R-30 000D33	34	MEETING HOUSE LN	JANET & SUSAN SHANNON	CAROLYN & NEAL OPALKA	34 MEETING HOUSE LN, #314	STOW	MA	01775	73852	38
00R-30 000D34	34	MEETING HOUSE LN	MEETING HOUSE AT STOW CONDOMINIUM T	C/O THE DARTMOUTH GROUP	4 PRESTON COURT STE 101	BEDFORD	MA	01730	51499	592
00R-30 000G10	0	FAXON DR	JONES, RITA P.	JONES, LAURIE R.	26 FAXON DR	STOW	MA	01775	75422	173
00R-30 000G11	0	FAXON DR	LYNCH EDMUND P	LYNCH GERALDINE D	28 FAXON DR	STOW	MA	01775	49233	164
00R-30 000G12	0	FAXON DR	HOWE, T. JEFFREY (TRUSTEE)	T. JEFFREY HOWE TRUST	30 FAXON DRIVE	STOW	MA	01775	72138	492
00R-30 0014-7	55	ELM RIDGE RD	COTE MICHAEL P	COTE SUSAN R	55 ELM RIDGE ROAD	STOW	MA	01775	49699	376
00R-30 0014-8	59	ELM RIDGE RD	MACLURE PAUL E	PATRICIA R MACLURE	59 ELM RIDGE ROAD	STOW	MA	01775	24168	569
00R-30 0014-9	67	ELM RIDGE RD	HERBST SR DAVID M	SHELLY M HERBST	67 ELM RIDGE ROAD	STOW	MA	01775	24534	65
00R-30 014-10	77	ELM RIDGE RD	PEDERSON VALERIE	PURINTON MARK	77 ELM RIDGE ROAD	STOW	MA	01775	27931	323
00R-30 014-11	83	ELM RIDGE RD	KYDD MATTHEW D	KYDD JENNIFER A	83 ELM RIDGE RD	STOW	MA	01775	63010	496
00R-30 014-12	89	ELM RIDGE RD	FARNSWORTH SAMUEL P	JOHNSON DONNA L	89 ELM RIDGE ROAD	STOW	MA	01775	37442	321
00R-30 014-13	86	ELM RIDGE RD	BROWN ROBERT	BROWN TARA	86 ELM RIDGE ROAD	STOW	MA	01775	53478	412
00R-30 014-14	82	ELM RIDGE RD	RACHAEL A RICCI	MICHAEL A DONOVAN	82 ELM RIDGE RD	STOW	MA	01775	73124	223
00R-30 014-15	76	ELM RIDGE RD	PIANTEDOSI, BARBARA A. & MARK A.	THE 2007 PIANTEDOSI FAMILY TRUST	76 ELM RIDGE RD	STOW	MA	01775	75936	67
00R-30 014-16	72	ELM RIDGE RD	MICHAEL PAPARISTO	SANDRA PAPARISTO	72 ELM RIDGE RD	STOW	MA	01775	72957	539
00R-30 014-17	68	ELM RIDGE RD	GRUMAN MARK	GRUMAN MEGAN	68 ELM RIDGE RD	STOW	MA	01775	62162	209
00R-30 014-18	58	ELM RIDGE RD	FARNSWORTH THOMAS M	FARNSWORTH ERIN M	58 ELM RIDGE ROAD	STOW	MA	01775	37428	117
00R-30 014-19	56	ELM RIDGE RD	ROGERS CHRISTOPHER	ROGERS JACQUELINE	56 ELM RIDGE ROAD	STOW	MA	01775	66851	115
00R-30 014-20	54	ELM RIDGE RD	LAMPLOUGH, PHILIP J. & DEBORAH B. (TTEES)	THE PHILIP AND DEBORAH LAMPLOUGH LIVIN	54 ELM RIDGE RD	STOW	MA	01775	77012	102
00R-30 015-1A	0	MEETING HOUSE LN	MEETING HOUSE AT STOW LLC		34 MEETING HOUSE LN	STOW	MA	01775	36095	110
00R-31 000015	0	TUTTLE LN	TOWN OF STOW	CONSERVATION COMMISSION	380 GREAT ROAD	STOW	MA	01775	14475	581
00R-31 000016	0	TUTTLE LN	MOREY, GEORGE (ETATE OF)		49 RIDGE RD	LEXINGTON	MA	02420	10716	244
00R-31 000018	200	RED ACRE RD	CAPONE DONALD J	CATHERINE F CAPONE	200 RED ACRE RD	STOW	MA	01775	12876	51
00R-31 000019	208	RED ACRE RD	FREEDMAN, F. PAULETTE & GARY M., TTEES	F. PAULETTE FREEDMAN REV TR 2021	208 RED ACRE RD	STOW	MA	01775	78736	251
00R-31 000055	172	RED ACRE RD	LYNCH WILLIAM	LYNCH JENNIFER M	172 RED ACRE RD	STOW	MA	01775	37483	231
00R-31 000056	196	RED ACRE RD	JOHNSON DOUGLAS	MARYFRAN JOHNSON	196 RED ACRE RD	STOW	MA	01775	22243	46

Certified by the Stow Board of Assessors:

D. Carter

Stuart Carter, MAA

Date Certified or Re-Certified:

8/8/22

Fr:

300

ABUTTERS LIST

R31/57A AND R30/20

00R-31 000058	189	SOUTH ACTON RD	STALZER STEVE C		189 SOUTH ACTON RD	STOW	MA	01775	71236	215
00R-31 000059	175	SOUTH ACTON RD	BUZZELL GREGORY S	LISA M BUZZELL	175 S ACTON RD	STOW	MA	01775	21730	577
00R-31 000060	169	SOUTH ACTON RD	CUMMING SCOTT M	CUMMING JEANNINE R	169 S ACTON RD	STOW	MA	01775	72353	188
00R-31 000061	165	SOUTH ACTON RD	KOWIT SARAH	SCHWAGER MICHAEL H	165 SOUTH ACTON RD	STOW	MA	01775	67252	144
00R-31 000062	159	SOUTH ACTON RD	DOANE JONATHAN P	DOANE ANDREANNA R	159 SOUTH ACTON ROAD	STOW	MA	01775	69121	421
00R-31 000063	155	SOUTH ACTON RD	MCCLELLAN GLADYS E		155 SOUTH ACTON RD	STOW	MA	01775	8309	594
00R-31 000064	149	SOUTH ACTON RD	MAGDALENO ROBERTO B	MAGDALENO MARTHA L	149 SOUTH ACTON ROAD	STOW	MA	01775	36006	394
00R-31 00057A	0	TUTTLE LN	STOW MUNICIPAL AFFORDABLE HOUSING TR	KOPCZYNSKI M, CLARK I, PAPANASTASSIOU C	380 GREAT ROAD	STOW	MA	01775	71090	375
00R-31 0055-1	186	RED ACRE RD	DOW MICHAEL D	DOW LAURA JEAN	186 RED ACRE RD	STOW	MA	01775	50292	357
00R-31 0055-2	178	RED ACRE RD	STARK, JEREMY	FEENEY, LAURA	178 RED ACRE RD	STOW	MA	01775	77734	279
00U-11 039C-1	0	DEER FIELD LN	TOWN OF STOW		380 GREAT ROAD	STOW	MA	01775	46919	256
* RECENT SALES										

Certified by the Stow Board of Assessors:



Stuart Carter, MAA

Date Certified or Re-Certified:

8/8/22 Ft: 300





75.18 ft²

boardwalk

Ministers Pond

Wed Mar 30 2022

Imagery © 2022 Nearmap, HERE

500 ft

nearmap